



**BROMED**  
INSTRUMENTS

Das Instrument.



*Chirurgische Instrumente Katalog*

**Gynäkologie**

*Catalogue des instruments chirurgicaux*

**Gynécologie**

*Catálogo de instrumentos quirúrgicos*

**Ginecología**

*Catalogo di strumenti chirurgici*

**Ginecologia**

*Catalogue of Surgical Instruments*

**Gynecology**





**BROMED**  
INSTRUMENTS



|  |                                |  |  |                         |               |                    |
|--|--------------------------------|--|--|-------------------------|---------------|--------------------|
|  | CLEAN AND STERILIZE BEFORE USE |  |  | AUTOCLAVE 132°C / 270°F | 135°C / 275°F | TIME 5 - 15' (min) |
|--|--------------------------------|--|--|-------------------------|---------------|--------------------|

**Instructions of use:** The instruments are supplied in NON STERILE condition. Clean and Sterilize before first use and each subsequent use. Remove eventual deposits of organic residue and other corrosive substances by using specifically adapted products, in the concentrations and times indicated by the manufacturer. It is necessary to implement periodical verification of the perfect operation of the sterilization apparatus, autoclave and other system used by the customer. Time and temperature standards for Autoclave (Steam Sterilization) and Chemiclave: 5 - 15 min. / 132°-135°C (270°-275°F). Instruments must be cleaned, bagged individually or bagged/wrapped in a tray setup, and then sterilized. A chemical/autoclave indicator device should be included in the wrapping. Hinged instruments must be processed open and unlocked. Do not combine different metals (chrome, stainless, titanium, etc.). Instrument sterilization cannot substitute cleaning. TC instruments (Tungsten carbide) should never be exposed to chemical substances. Do not use ultrasonic cleaning for TC instruments, sharp and delicate instruments. Cutting instruments must be kept sharp (sharpening stones improves shelf life). Check scissors and cutting instruments for proper alignment and sharpness (latex glove test, teflon testing stick). Lubricate hinged instruments (prevents rust, corrosion and still joints). A correctly maintained instrument can have a life cycle of 5 years. Non-Conformity to these fundamental rules can damage the instrument beyond repair and will cancel any BMT product guarantee with respect to repair or refund claims. The warranty does not cover general maintenance (ex: sharpening, spring/screw/Tungsten-Carbide insert replacement). BMT instruments are subject to Directive 93/42/CEE and therefore are to be sold according to the applicable regional norms. For more information visit our website.

# Gynecology

Gynäkologie  
 Gynécologie  
 Ginecología  
 Ginecologia

## Table of Contents

### Gynecology Instruments

- Kidney Stone Forceps .....4
- Catheters | Metal Probes .....5
- Gall Duct Dilators .....6
- Intestines | Urology .....8
- Cotton Swab Forceps | Hemostatic Forceps ..... 11
- Vaginal Specula | Retractors ..... 12
- Endocervical Specula ..... 20
- Uterine Dilators ..... 21
- Uterine Sounds ..... 25
- Uterine Forceps ..... 26
- Myoma | Micro-Tube Instruments ..... 28
- Uterine Biopsy Aspirating Curettes ..... 29
- Biopsy Forceps ..... 30
- Uterine Curettes ..... 33

### Instrument Care

- Cleaning, Maintenance and Sterilization of Surgical Instruments ..... 36
- Maintenance Cycle and Tips ..... 37

### Index

- Alphanumerical Index ..... 38



*This catalog displays an abbreviated summary of our products. A complete selection of all our instruments, catalogues and instructions of use are available on our website. BMT quality warranty against manufacturer defects. German stainless steel. We make custom design kits items to meet with specific needs of professionals.*

# Kidney Stone Forceps

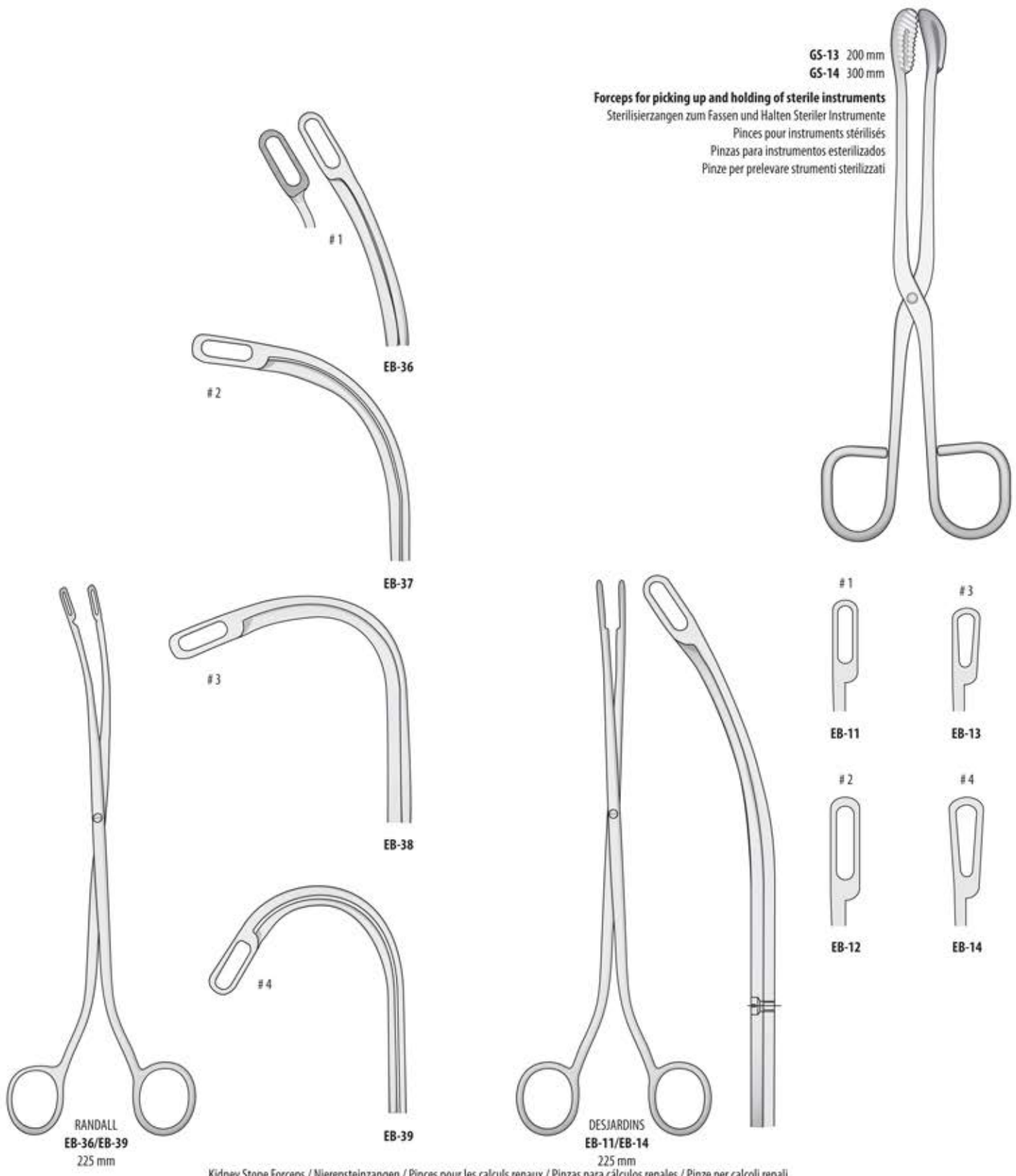

Kidney Stone Forceps / Nierensteinzangen / Pinces pour les calculs renaux / Pinzas para cálculos renales / Pinze per calcoli renali

# Catheters | Metal Probes

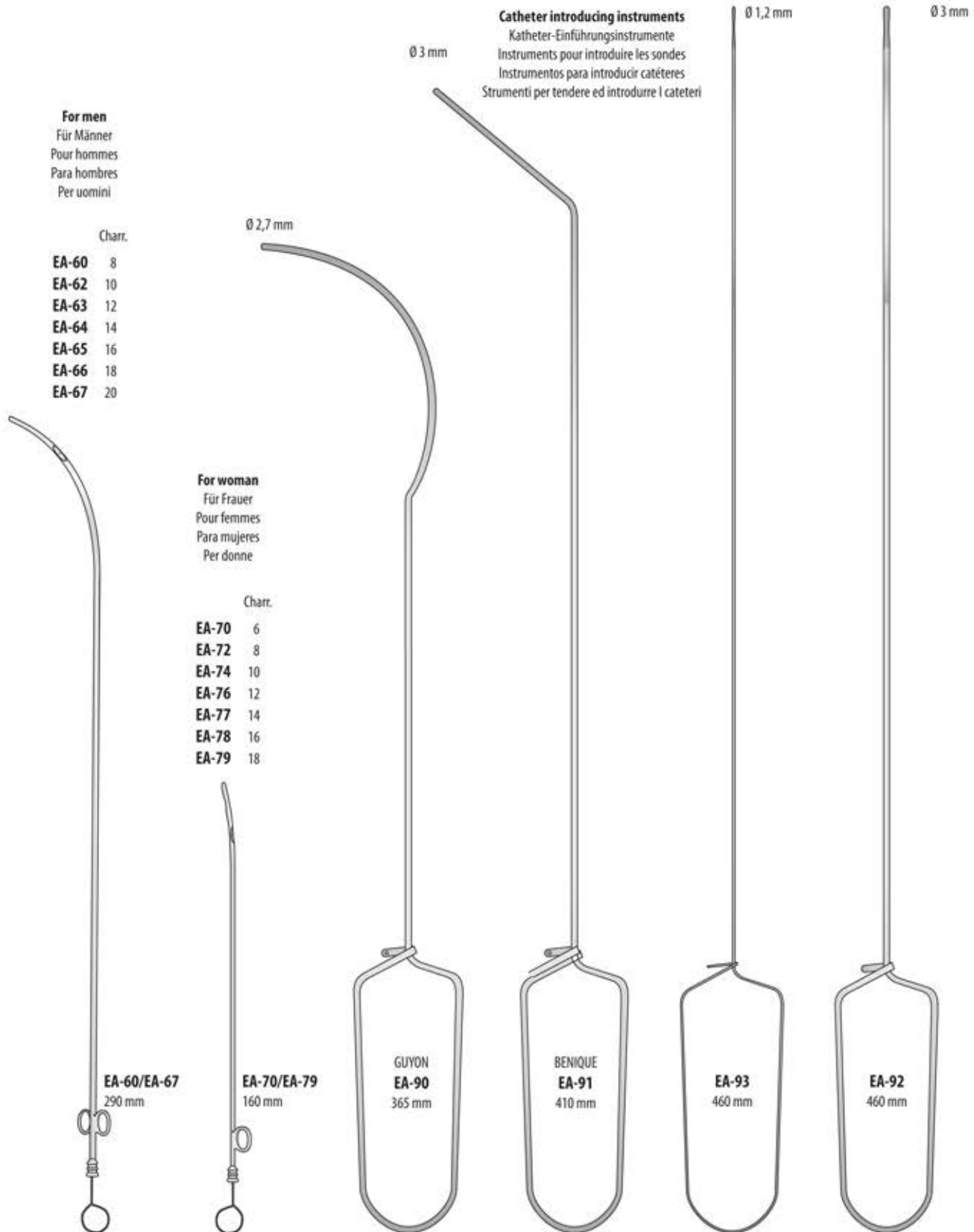

Catheters - Metal Probes / Katheterspanner - Metallkatheter / Cathéters - Sondes métalliques / Catéteres - Sondas metálicas / Cateteri - Sonde metalliche

# Gall Duct Dilators

**EB-250**  
**Complete set with 19 pieces - Ch.12 / Ch.30**  
 Komplettsset mit 19 Stück - Ch.12 / Ch.30  
 Set complet avec 19 pièces - Ch.12 / Ch.30  
 Set completo con 19 piezas - Ch.12 / Ch.30  
 Set completo con 19 pezzi - Ch.12 / Ch.30

**Gall Stone Probes**  
 Gallensteinsonden  
 Explorateurs pour calculs biliaires  
 Exploradores para cálculos biliares  
 Sonde per dotto biliare

**Flexible**  
 Flexibel  
 Flexible  
 Flexible  
 Flessibile

**FB-321** - 190 mm - Ø 3 mm  
**FB-322** - 190 mm - Ø 4 mm  
**FB-323** - 190 mm - Ø 5 mm  
**FB-324** - 190 mm - Ø 6 mm  
**FB-325** - 190 mm - Ø 7 mm  
**FB-326** - 190 mm - Ø 8 mm  
**FB-327** - 190 mm - Ø 9 mm  
**FB-328** - 190 mm - Ø 10 mm  
**FB-329** - 190 mm - Ø 11 mm

**FB-320**  
**Set of 9 pieces in canvas pocket**  
 Satz à 9 Stück in Leinentuchtasche  
 Jeu de 9 pièces dans une poche en toile  
 Juego de 9 unidades en bolsa de tela  
 Set di 9 pezzi con custodia

**FB-331** - 300 mm - Ø 1 mm  
**FB-332** - 300 mm - Ø 2 mm  
**FB-333** - 300 mm - Ø 3 mm  
**FB-334** - 300 mm - Ø 4 mm  
**FB-335** - 300 mm - Ø 5 mm  
**FB-336** - 300 mm - Ø 6 mm  
**FB-337** - 300 mm - Ø 7 mm  
**FB-338** - 300 mm - Ø 8 mm  
**FB-339** - 300 mm - Ø 9 mm  
**FB-340** - 300 mm - Ø 10 mm  
**FB-341** - 300 mm - Ø 11 mm  
**FB-342** - 300 mm - Ø 12 mm  
**FB-343** - 300 mm - Ø 13 mm

**FB-330**  
**Set of 13 pieces**  
 Satz à 13 Stück  
 Jeu de 13 pièces  
 Juego de 13 unidades  
 Set di 13 pezzi

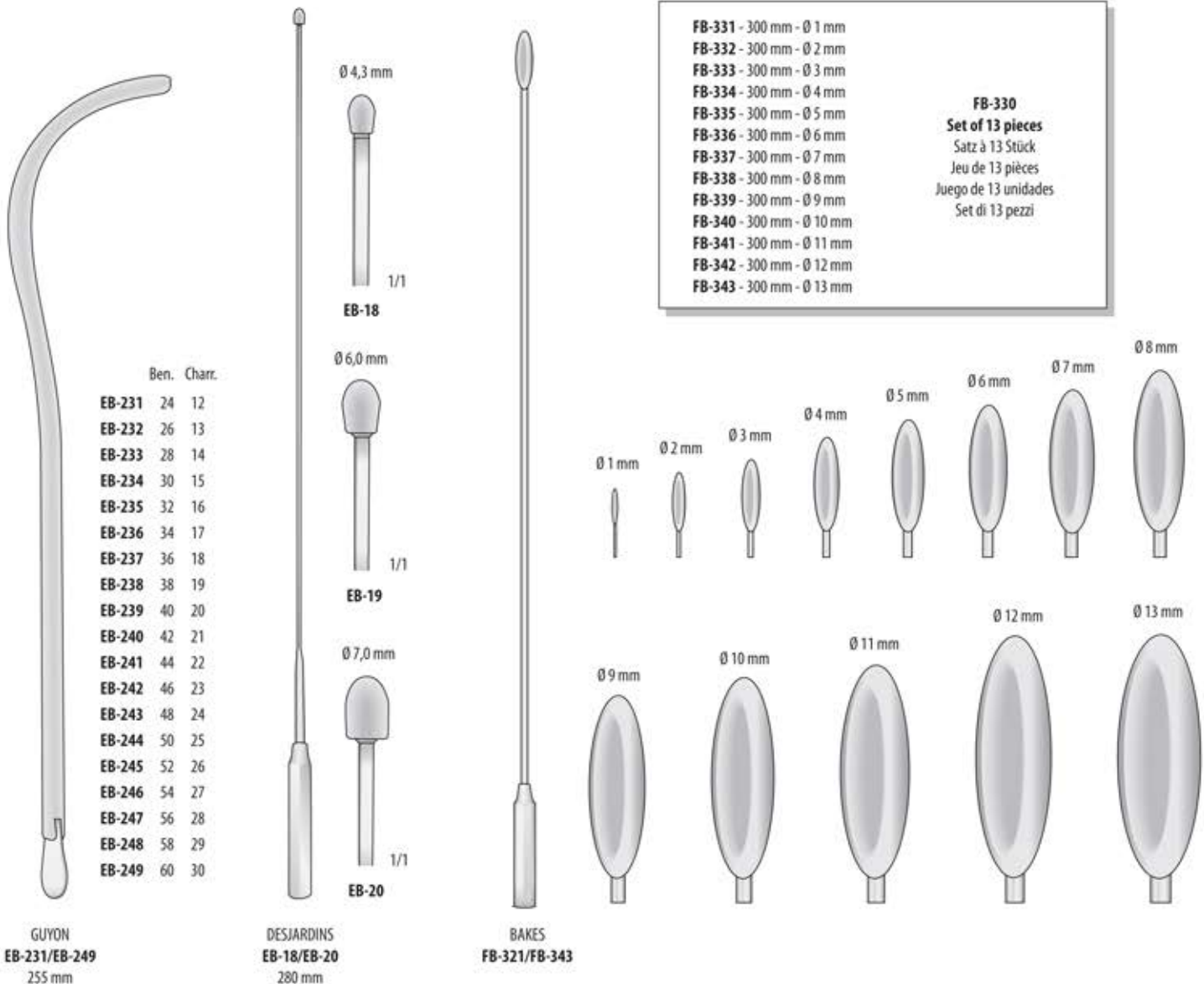

Gall Duct Dilators / Gallengang-Dilatatoren / Dilatateurs pour les voies biliaires / Dilatadores para conductos biliares / Dilatatori per vie biliari

# Gall Duct Dilators

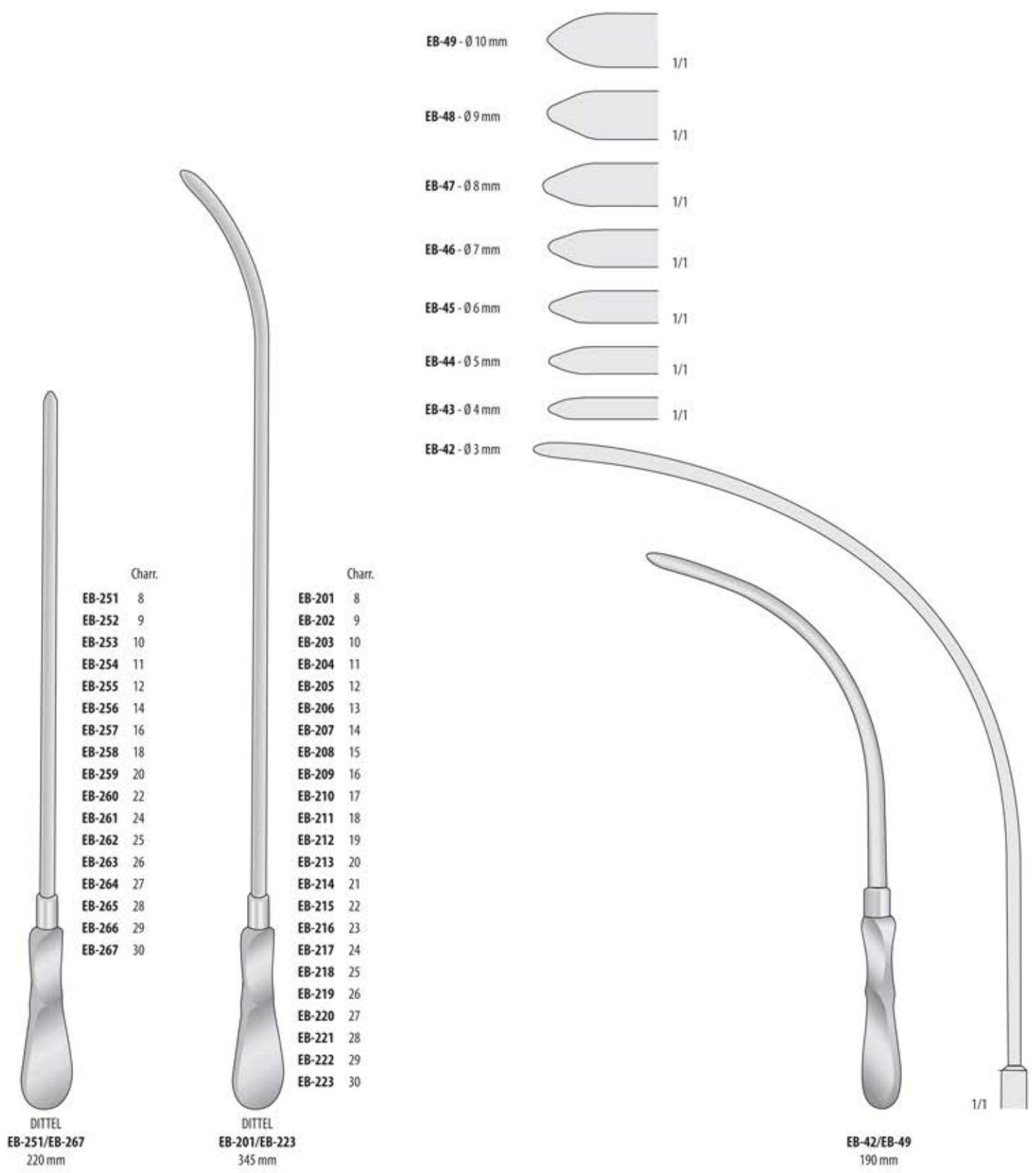

| Model  | Charr. |
|--------|--------|
| EB-251 | 8      |
| EB-252 | 9      |
| EB-253 | 10     |
| EB-254 | 11     |
| EB-255 | 12     |
| EB-256 | 14     |
| EB-257 | 16     |
| EB-258 | 18     |
| EB-259 | 20     |
| EB-260 | 22     |
| EB-261 | 24     |
| EB-262 | 25     |
| EB-263 | 26     |
| EB-264 | 27     |
| EB-265 | 28     |
| EB-266 | 29     |
| EB-267 | 30     |

**DITTEL**  
EB-251/EB-267  
220 mm

| Model  | Charr. |
|--------|--------|
| EB-201 | 8      |
| EB-202 | 9      |
| EB-203 | 10     |
| EB-204 | 11     |
| EB-205 | 12     |
| EB-206 | 13     |
| EB-207 | 14     |
| EB-208 | 15     |
| EB-209 | 16     |
| EB-210 | 17     |
| EB-211 | 18     |
| EB-212 | 19     |
| EB-213 | 20     |
| EB-214 | 21     |
| EB-215 | 22     |
| EB-216 | 23     |
| EB-217 | 24     |
| EB-218 | 25     |
| EB-219 | 26     |
| EB-220 | 27     |
| EB-221 | 28     |
| EB-222 | 29     |
| EB-223 | 30     |

**DITTEL**  
EB-201/EB-223  
345 mm

| Model | Diameter | Ratio |
|-------|----------|-------|
| EB-49 | 1.0 mm   | 1/1   |
| EB-48 | 0.9 mm   | 1/1   |
| EB-47 | 0.8 mm   | 1/1   |
| EB-46 | 0.7 mm   | 1/1   |
| EB-45 | 0.6 mm   | 1/1   |
| EB-44 | 0.5 mm   | 1/1   |
| EB-43 | 0.4 mm   | 1/1   |
| EB-42 | 0.3 mm   | 1/1   |

**EB-42/EB-49**  
190 mm

Gall Duct Dilators / Gallengang-Dilatatoren / Dilatateurs pour les voies biliaires / Dilatadores para conductos biliares / Dilatatori per vie biliari

**Intestines | Urology**

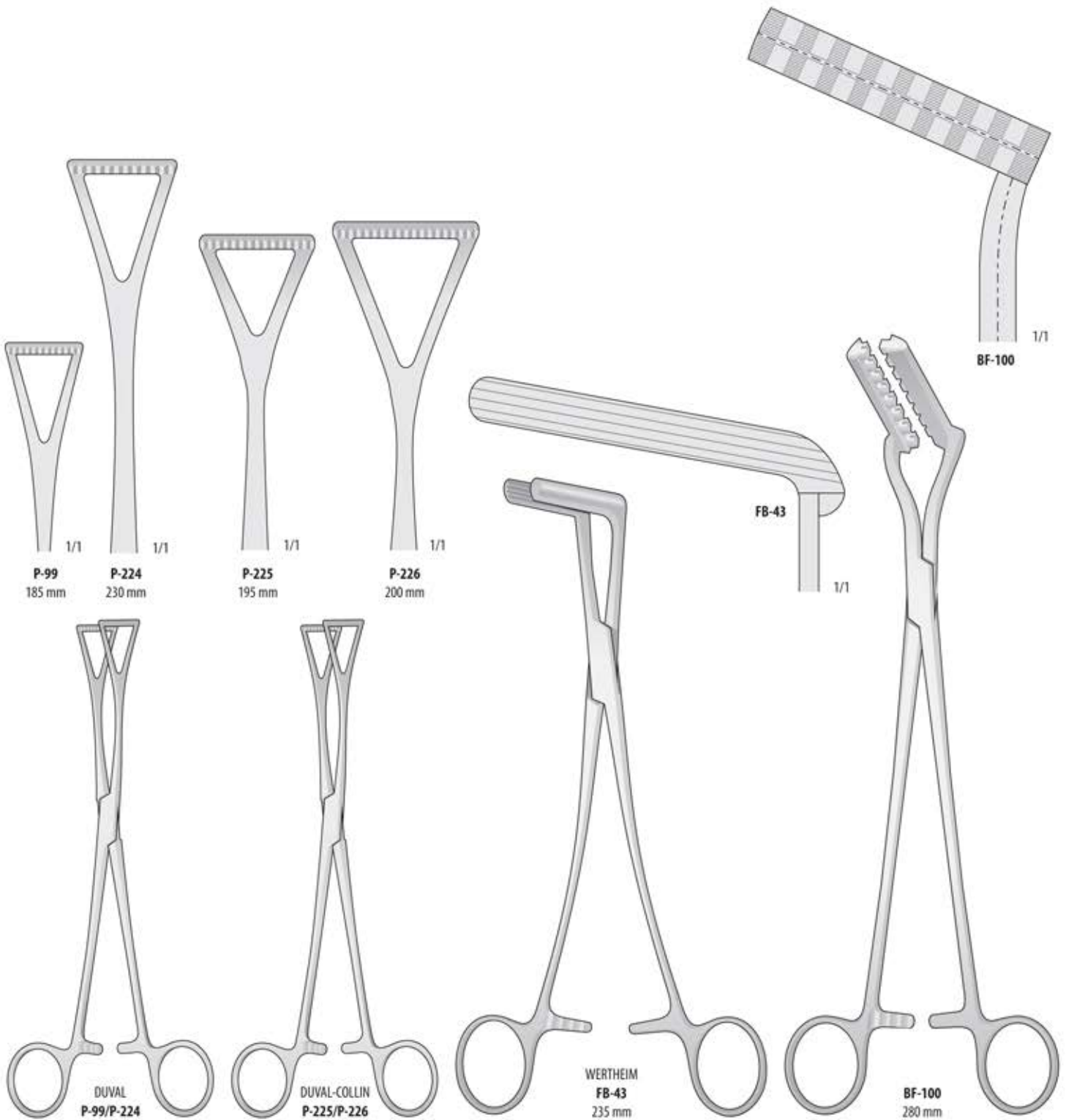

Intestines - Urology / Darm - Urologie / Intestins - Urologie / Intestinos - Urologia / Intestino - Urologia



**Intestines | Urology**

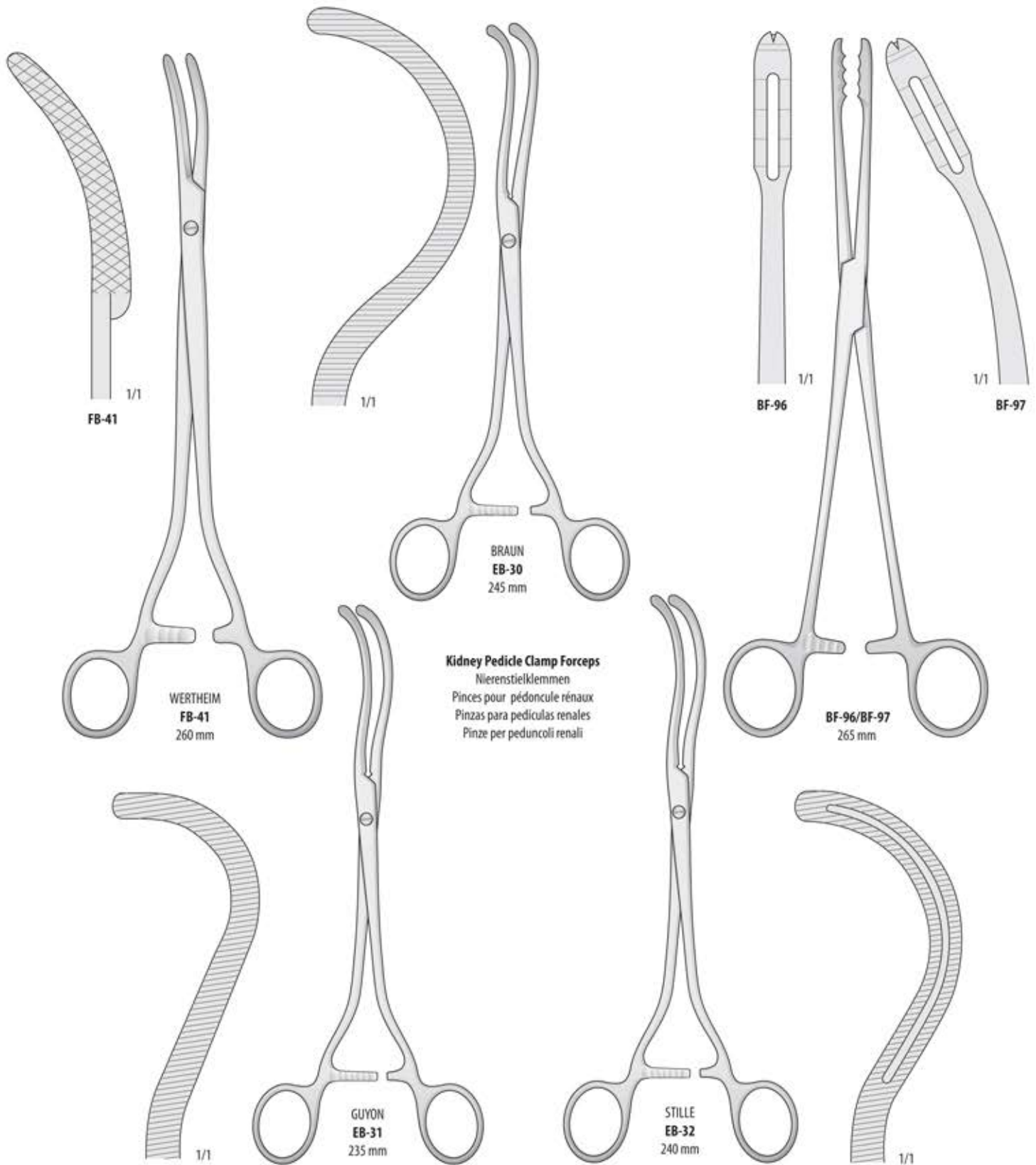

Intestines - Urology / Darm - Urologie / Intestins - Urologie / Intestinos - Urologia / Intestino - Urologia

**Intestines | Urology**

**Kidney Pedicle Clamp Forceps**

Nierenstielklemmen  
Pincès pour pédoncule rénaux  
Pinzas para pedículas renales  
Pinze per peduncoli renali

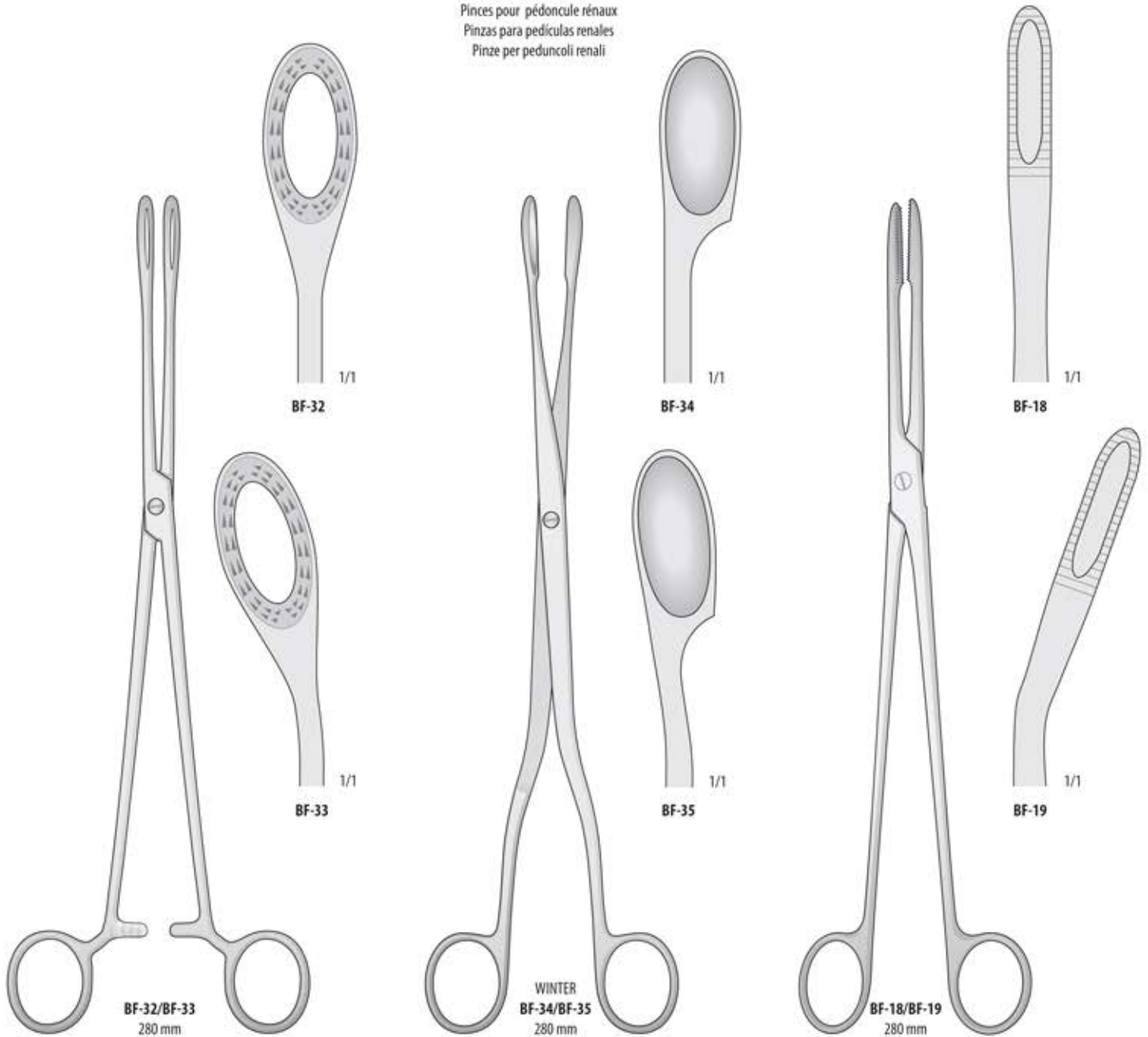

Intestines - Urology / Darm - Urologie / Intestins - Urologie / Intestinos - Urologia / Intestino - Urologia

## Cotton Swab Forceps | Hemostatic Forceps

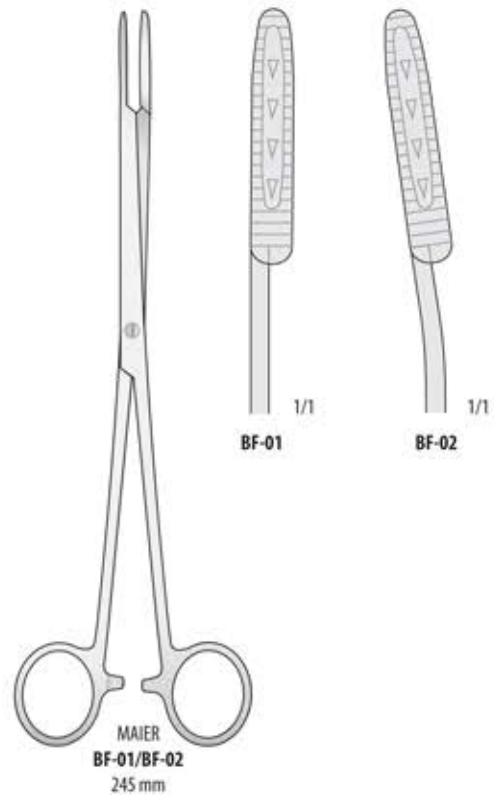
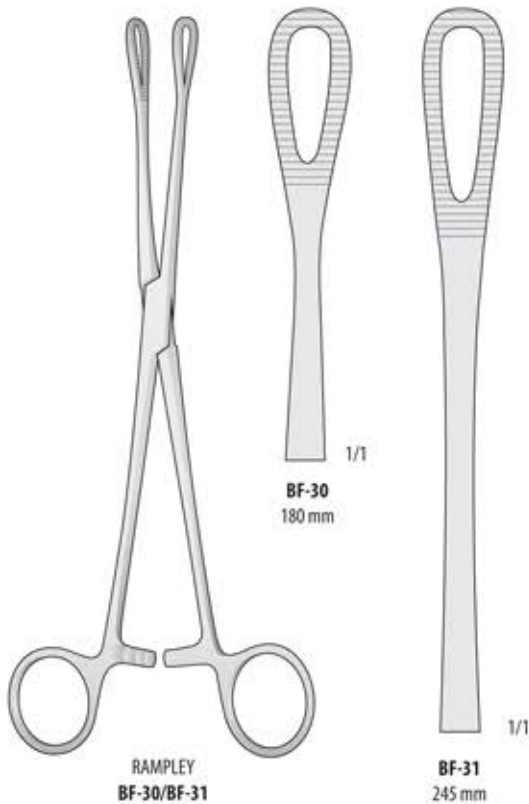
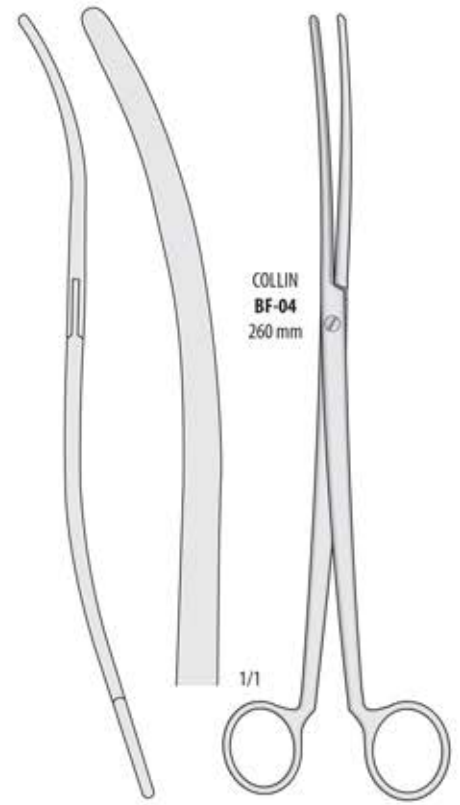
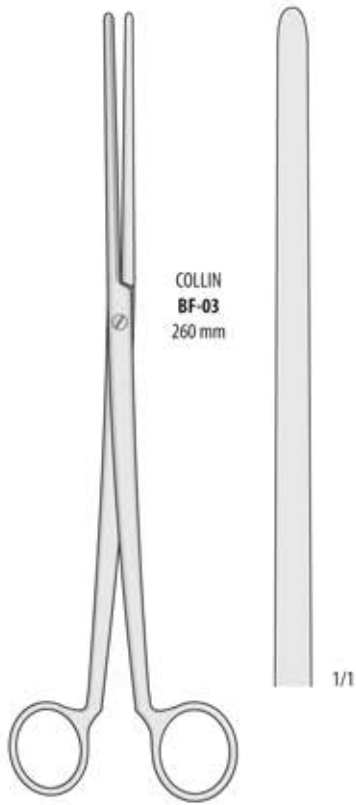

Cotton Swab Forceps - Hemostatic Forceps / Tupferzangen - Arterienklemmen / Pincas à tampons - Pincas hemostáticas / Pinzas para tampones - Pinzas hemostáticas / Pinze per tamponi - Pinze emostatiche

## Vaginal Specula | Retractors

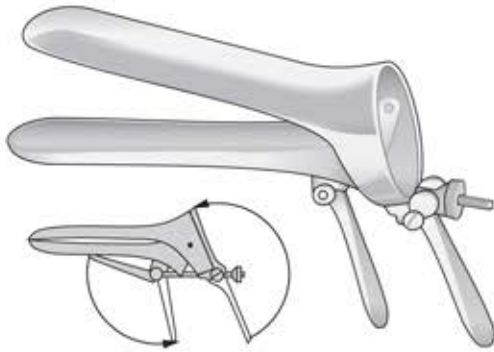

**CUSCO**  
**ER-49** #0 77x17 mm  
**ER-48** #1 75x33 mm  
**ER-47** #2 86x36 mm  
**ER-46** #3 97x36 mm

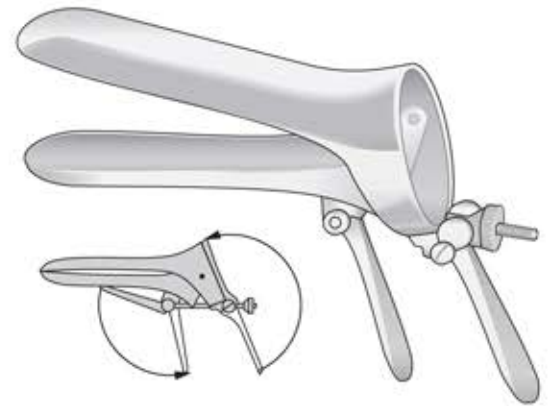

**CUSCO**  
**SCHWEIZER MODELL**  
**ER-61** #1 90x23 mm  
**ER-62** #2 100x24 mm  
**ER-63** #3 105x27 mm

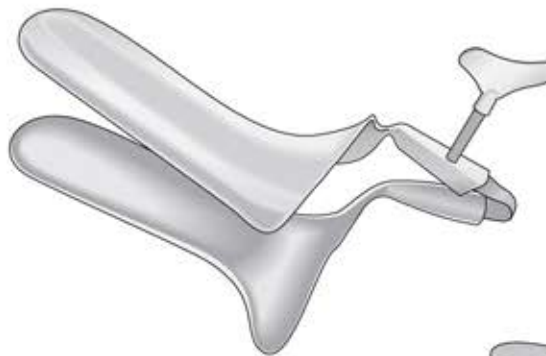

**COLLIN-STANDARD**  
**ER-72** #1 90x29 mm  
**ER-73** #2 95x35 mm  
**ER-74** #3 110x40 mm



**GRAVE**  
**ER-91** 75x20 mm  
**ER-92** 95x30 mm  
**ER-93** 105x33 mm



**PEDERSON**  
**ER-96** 100x22 mm  
**ER-97** 120x25 mm

Vaginal Specula and Retractors / Vaginalspekula und Retraktoren / Spéculum et Valves vaginaux / Espéculos y valvas vaginales / Speculum e valve vaginali

## Vaginal Specula | Retractors

**Antireflective surface (black)**  
Antireflex-Oberfläche (schwarz)  
Surface antireflet (noir)  
Superficie antireflejo (negro)  
Superficie anti-riflesso (nero)



**ER-60**  
120 x 25 mm

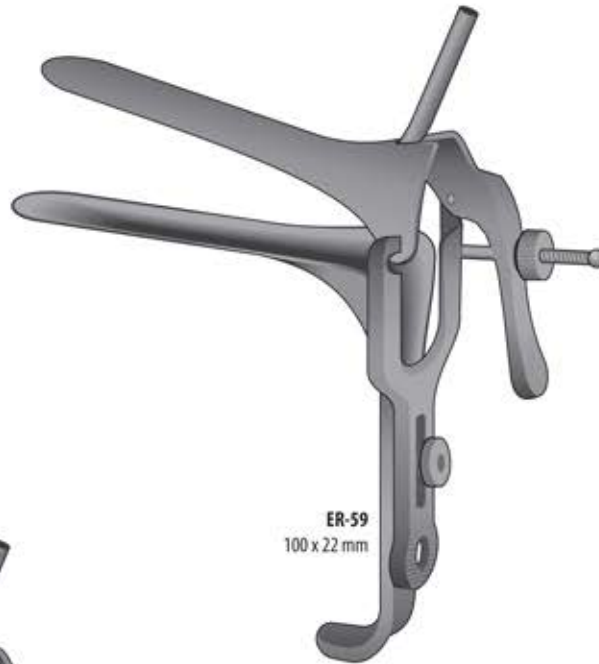

**ER-59**  
100 x 22 mm



**ER-58**  
75 x 20 mm

Vaginal Specula and Retractors / Vaginalspekula und Retraktoren / Spéculum et Valves vaginaux / Espéculos y valvas vaginales / Speculum e valve vaginali

## Vaginal Specula | Retractors

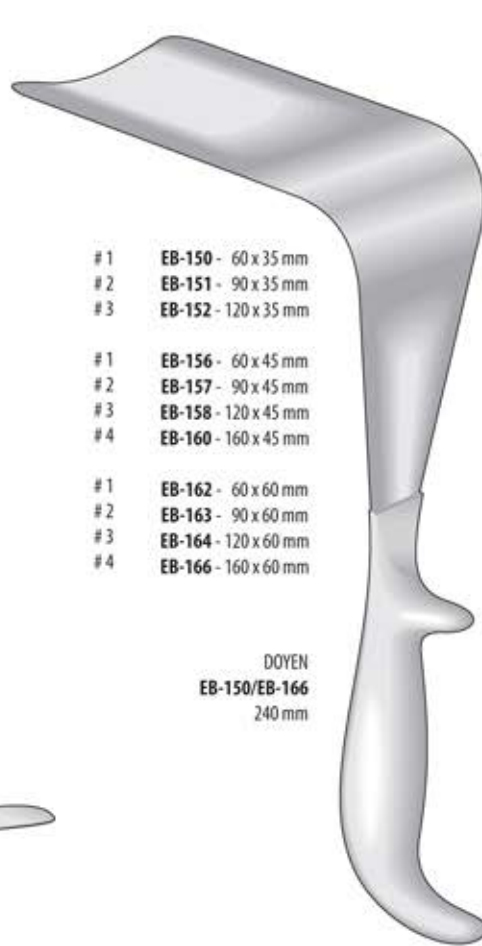

- # 1 **EB-150** - 60 x 35 mm
- # 2 **EB-151** - 90 x 35 mm
- # 3 **EB-152** - 120 x 35 mm
  
- # 1 **EB-156** - 60 x 45 mm
- # 2 **EB-157** - 90 x 45 mm
- # 3 **EB-158** - 120 x 45 mm
- # 4 **EB-160** - 160 x 45 mm
  
- # 1 **EB-162** - 60 x 60 mm
- # 2 **EB-163** - 90 x 60 mm
- # 3 **EB-164** - 120 x 60 mm
- # 4 **EB-166** - 160 x 60 mm

DOYEN  
**EB-150/EB-166**  
240 mm



95 x 17 - 30 mm

MATHIEU  
**EB-106**  
210 mm

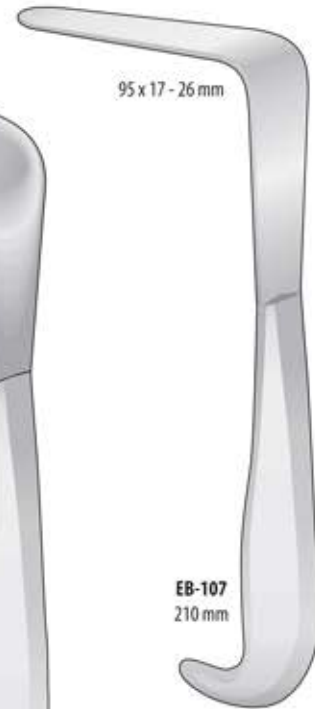

95 x 17 - 26 mm

**EB-107**  
210 mm



KALLMORGEN  
**EB-101** - 70 x 40 mm  
170 mm

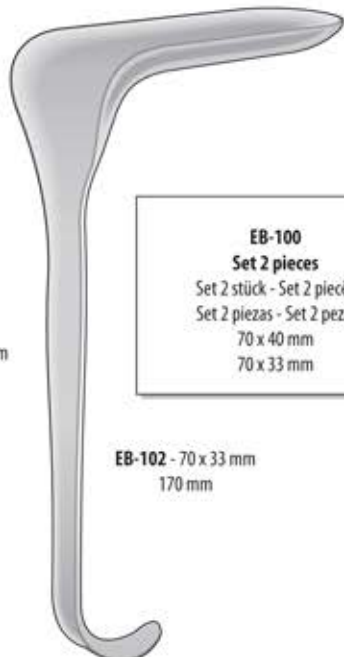

**EB-100**  
Set 2 pieces  
Set 2 stück - Set 2 pièces  
Set 2 piezas - Set 2 pezzi  
70 x 40 mm  
70 x 33 mm

**EB-102** - 70 x 33 mm  
170 mm

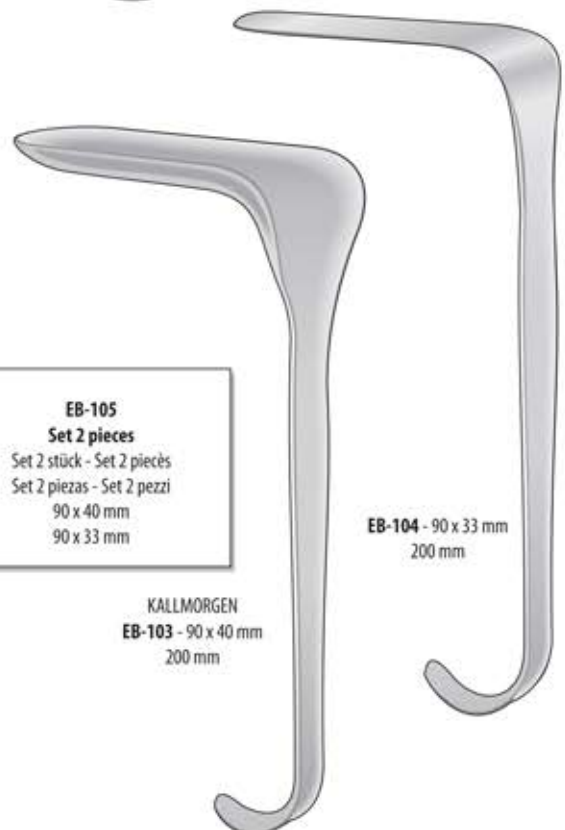

**EB-105**  
Set 2 pieces  
Set 2 stück - Set 2 pièces  
Set 2 piezas - Set 2 pezzi  
90 x 40 mm  
90 x 33 mm

KALLMORGEN  
**EB-103** - 90 x 40 mm  
200 mm

**EB-104** - 90 x 33 mm  
200 mm

Vaginal Specula and Retractors / Vaginalspekula und Retraktoren / Spéculum et Valves vaginaux / Espéculos y valvas vaginales / Speculum e valve vaginali

## Vaginal Specula | Retractors



**Specula**  
Spekula  
Spéculum  
Espéculo  
Speculum

KRISTELLER

- # 1 **EB-120** - 70 x 27 mm
- # 2 **EB-121** - 75 x 30 mm
- # 3 **EB-122** - 90 x 36 mm



**Retractor**  
Retraktor  
Valve  
Valva  
Valve

KRISTELLER

- # 1 **EB-123** - 75 x 23 mm
- # 2 **EB-124** - 80 x 26 mm
- # 3 **EB-125** - 95 x 32 mm



**Specula + Retractor**  
Spekula + Retraktor  
Spéculum + Valve  
Espéculo + Valva  
Speculum + Valve

- # 1 **EB-126**
- # 2 **EB-127**
- # 3 **EB-128**

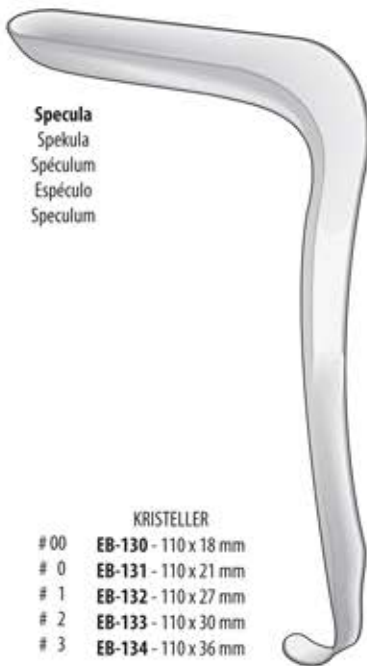

**Specula**  
Spekula  
Spéculum  
Espéculo  
Speculum

KRISTELLER

- # 00 **EB-130** - 110 x 18 mm
- # 0 **EB-131** - 110 x 21 mm
- # 1 **EB-132** - 110 x 27 mm
- # 2 **EB-133** - 110 x 30 mm
- # 3 **EB-134** - 110 x 36 mm



**Retractor**  
Retraktor  
Valve  
Valva  
Valve

KRISTELLER

- # 00 **EB-135** - 115 x 14 mm
- # 0 **EB-136** - 115 x 17 mm
- # 1 **EB-137** - 115 x 23 mm
- # 2 **EB-138** - 115 x 26 mm
- # 3 **EB-139** - 115 x 32 mm

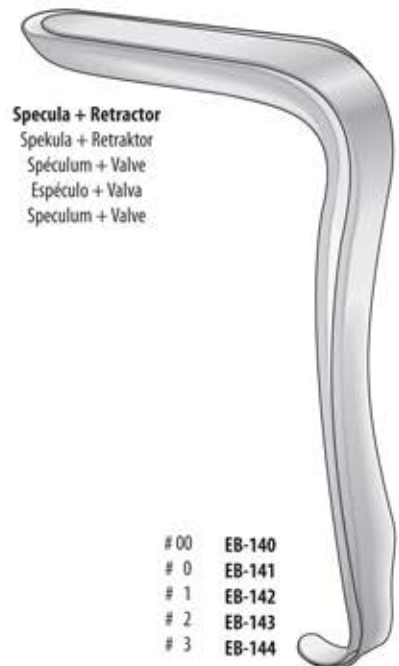

**Specula + Retractor**  
Spekula + Retraktor  
Spéculum + Valve  
Espéculo + Valva  
Speculum + Valve

- # 00 **EB-140**
- # 0 **EB-141**
- # 1 **EB-142**
- # 2 **EB-143**
- # 3 **EB-144**

Vaginal Specula and Retractors / Vaginalspekula und Retraktoren / Spécums et Valves vaginaux / Espéculos y valvas vaginales / Speculum e valve vaginali

## Vaginal Specula | Retractors



LANDAU  
**EB-190** - 100 x 28 mm  
**EB-191** - 100 x 38 mm  
 290 mm

BREISKY  
**EB-170** - 100 x 20 mm  
**EB-171** - 100 x 25 mm  
**EB-172** - 100 x 30 mm  
**EB-173** - 100 x 35 mm  
**EB-174** - 100 x 40 mm  
 290 mm

BREISKY  
**EB-175** - 130 x 20 mm  
**EB-176** - 130 x 25 mm  
**EB-177** - 130 x 30 mm  
**EB-178** - 130 x 35 mm  
**EB-179** - 130 x 40 mm  
 320 mm

BREISKY  
**EB-184** - 160 x 40 mm  
 350 mm

BREISKY  
**EB-189** - 180 x 40 mm  
 370 mm

Vaginal Specula and Retractors / Vaginalspekula und Retraktoren / Spéculum et Valves vaginaux / Espéculos y valvas vaginales / Speculum e valve vaginali



## Vaginal Specula | Retractors

**Midwifery Forceps**  
 Geburtszange  
 Forceps obstétrical  
 Forceps obstétrico  
 Forcipe ostetrico

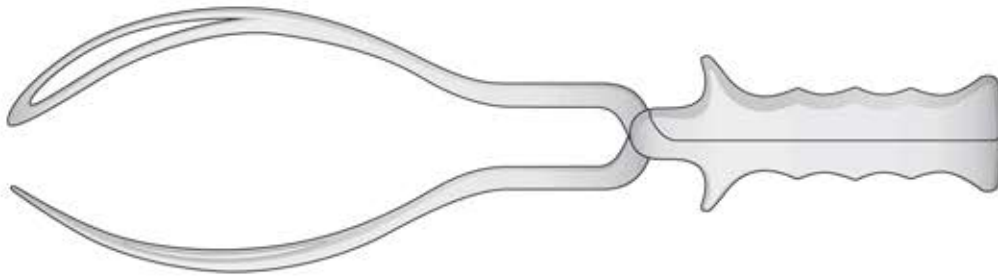

**SIMPSON-BRAUN**  
**ER-52**  
 365 mm

**ER-53**  
 Set 2 pieces  
 Set 2 Stück  
 Set 2 pièces  
 Set 2 piezas  
 Set 2 pezzi  
 (ER-50 + ER-51)

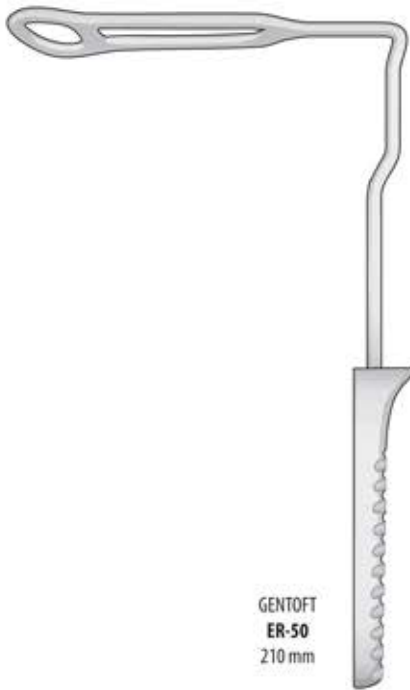

**GENTOFT**  
**ER-50**  
 210 mm



**FENO**  
**ER-51**  
 230 mm

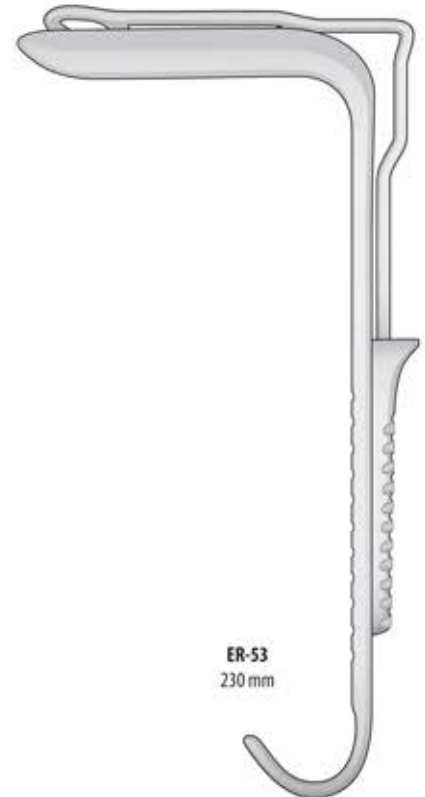

**ER-53**  
 230 mm

## Vaginal Specula | Retractors

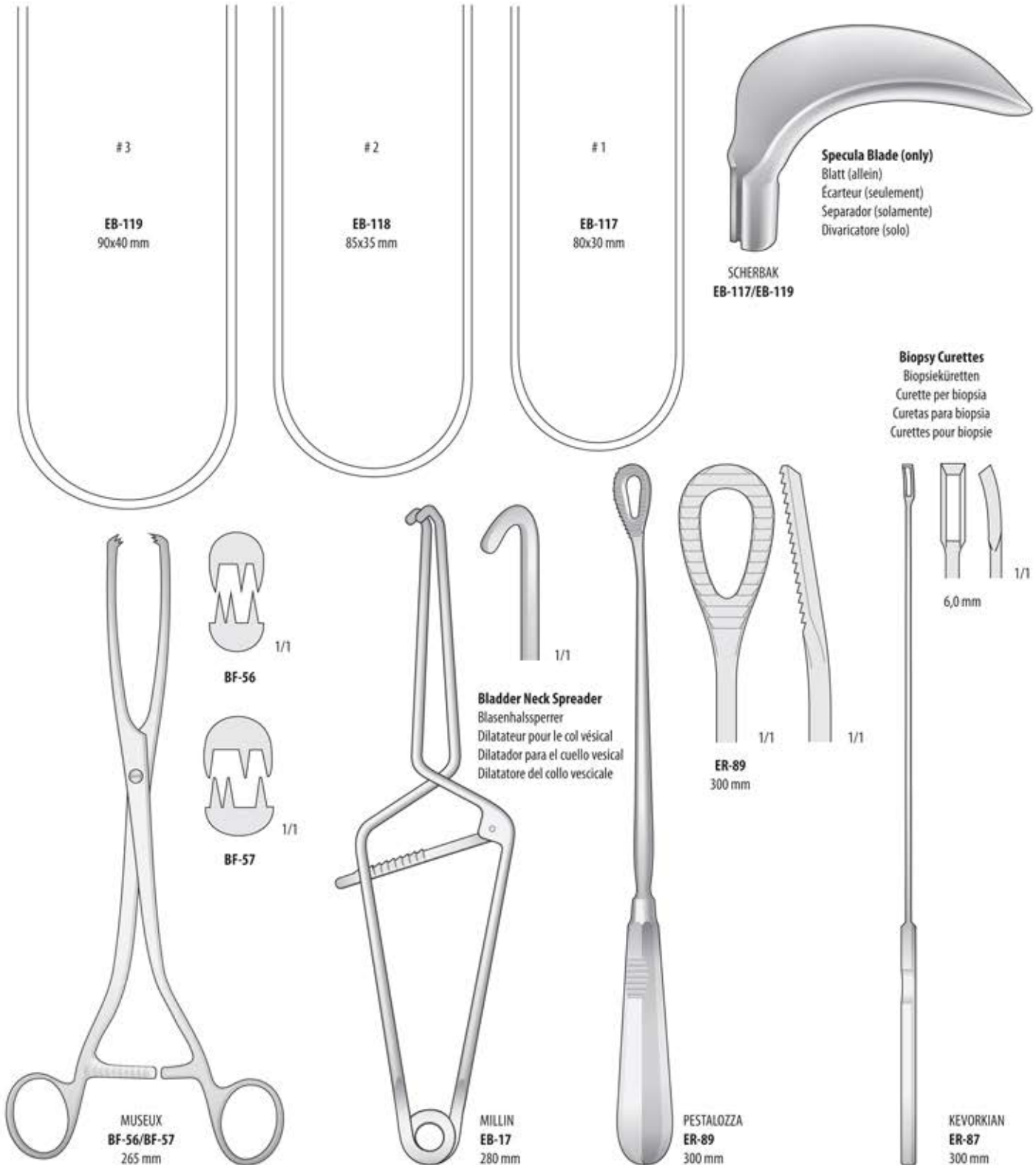

Vaginal Specula and Retractors / Vaginalspekula und Retraktoren / Spéculum et Valves vaginaux / Espéculos y valvas vaginales / Speculum e valve vaginali

## Vaginal Specula | Retractors

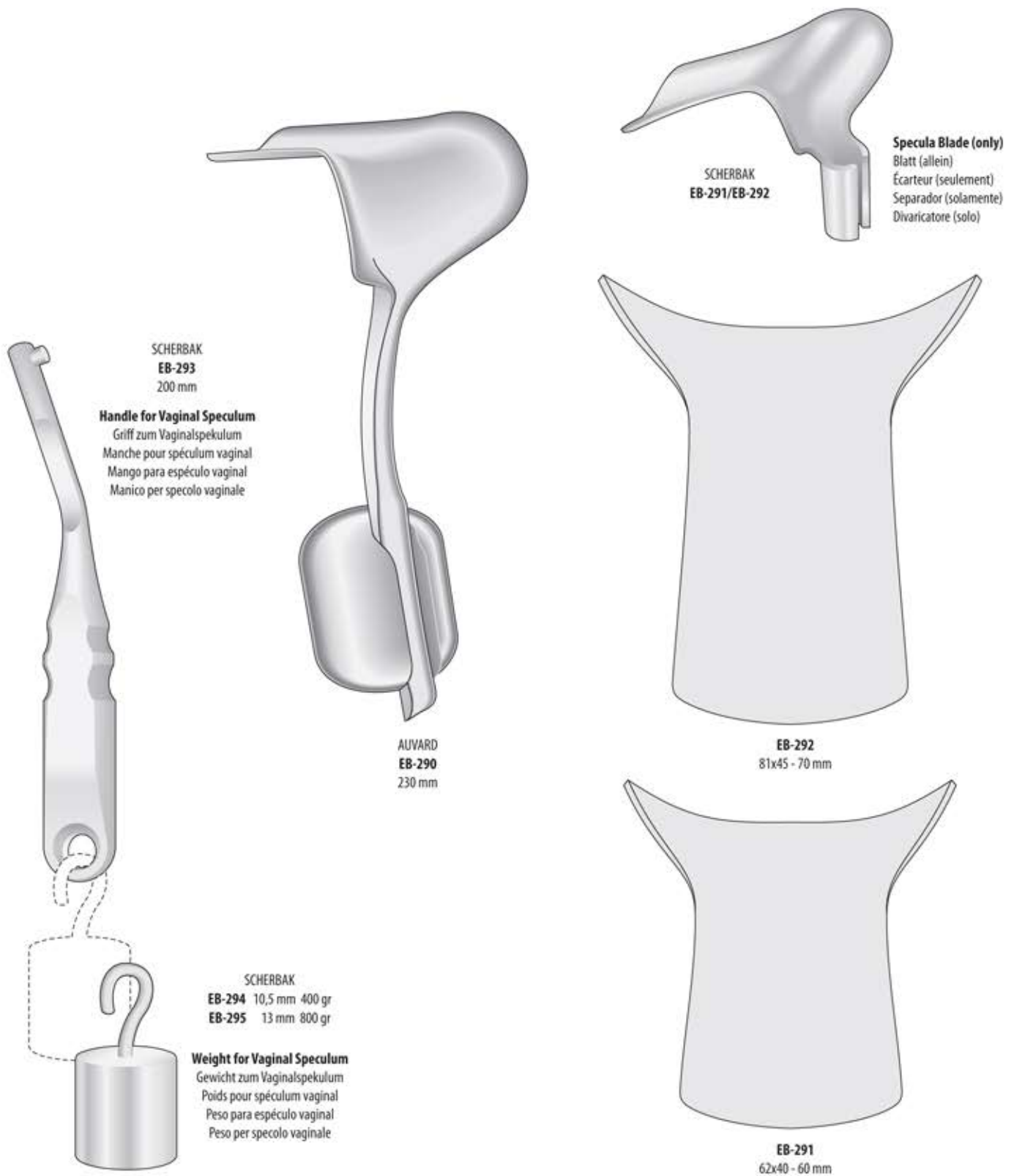

Vaginal Specula and Retractors / Vaginalsekula und Retraktoren / Spéculums et Valves vaginaux / Espéculos y valvas vaginales / Speculum e valve vaginali

## Endocervical Specula

**Endo Specula for cervix and urethra**  
 Endospekula für Harnröhre und Cervix  
 Endo Spéculum pour col de l'utérus et urètre  
 Espécula para cuello uterino y uretra  
 Endo Specula per la cervice e l'uretra

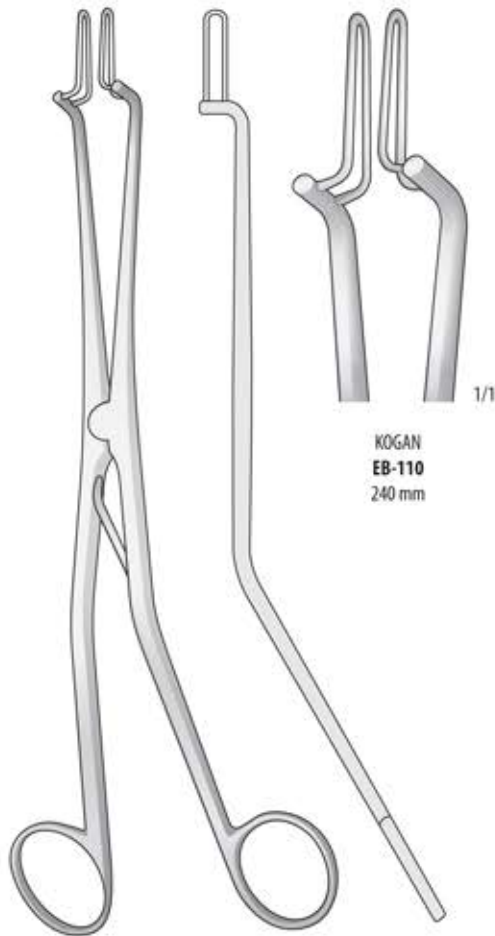

KOGAN  
**EB-110**  
 240 mm

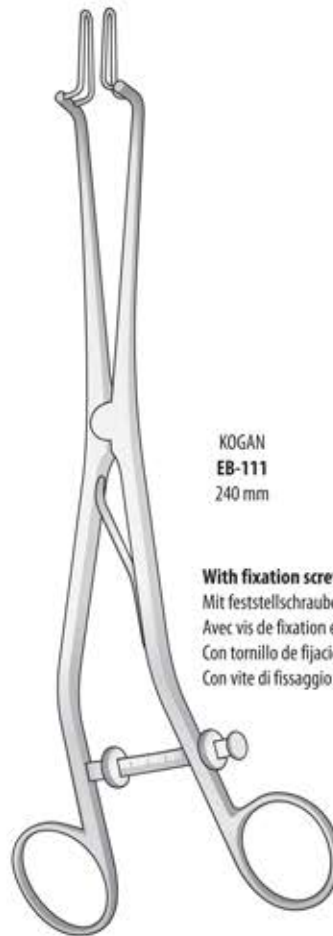

KOGAN  
**EB-111**  
 240 mm

**With fixation screw and ratchet (graduated)**  
 Mit feststellschraube und zahnsperre (einteilung)  
 Avec vis de fixation et crémaillère (graduée)  
 Con tornillo de fijación y cremallera (graduado)  
 Con vite di fissaggio e cremagliera (graduato)

Ø 1,2 mm

**Catheter introducing instrument**  
 Katheter-Einführungsinstrument  
 Instrument pour introduire les sondes  
 Instrumento para introducir catéteres  
 Strumento per tendere ed introdurre i cateteri



**EA-94**  
 425 mm

## Uterine Dilators

**Hegar Dilators**  
 Hegar Dilatoren  
 Dilateurs Hegar  
 Diladores Hegar  
 Dilatori Hegar

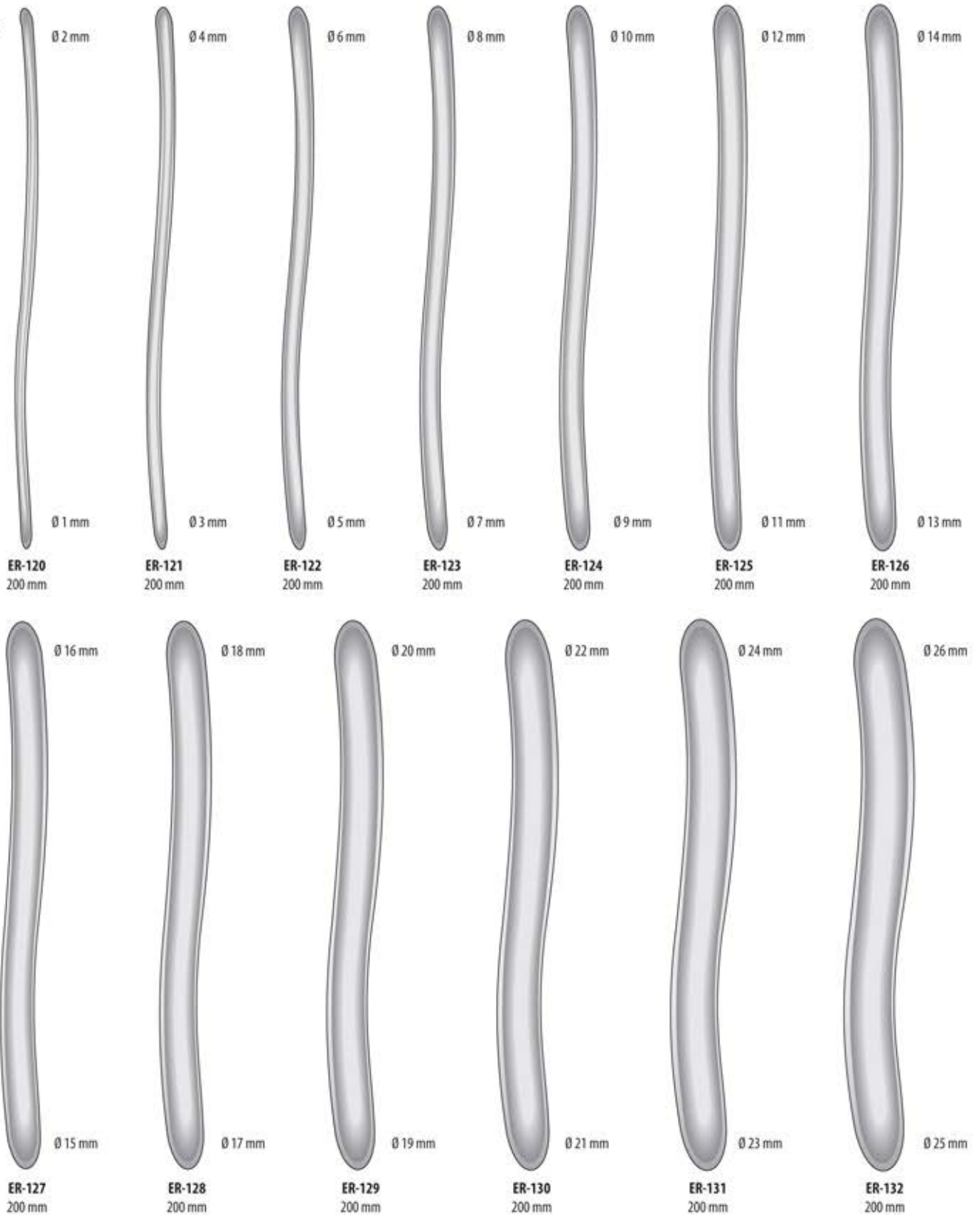

Uterine Dilators | Uterus-Dilatoren | Dilateurs utérins | Diladores uterinos | Dilatori uterini

# Uterine Dilators

**EB-94**  
Complete Set with 14 Hegar Uterine Dilators



**EB-96**  
Cassette with 14 Hegar Uterine Dilators

**EB-95**  
Complete Set with 26 Hegar Uterine Dilators



**ER-134**  
Cassette with 13 Hegar Uterine Dilators



**ER-133**  
Container with 8 Uterine Dilators



**ER-135**  
Container for 8 Uterine Dilators



**EB-97**  
Cassette with 26 Hegar Uterine Dilators

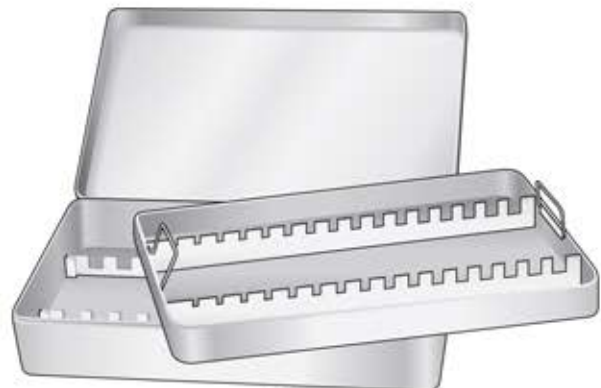

**BS-17**  
Cassette for 26 Hegar Uterine Dilators

Uterine Dilators | Uterus-Dilatatoren | Dilatateurs utérins | Dilatadores uterinos | Dilatatori uterini

## Uterine Dilators

|  |  | #     | mm        |
|--|--|-------|-----------|
| <b>Pratt Dilators</b><br>Pratt Dilatoren<br>Dilateurs Pratt<br>Dilatadores Pratt<br>Dilatatori Pratt | <b>ER-110</b>                            | 13/15 | 4,5/5,0   |
|  | <b>Set complete with 8 pieces</b>        | 17/19 | 5,6/6,3   |
|  | <b>Satz-Dilatator, komplett, 8 Stück</b> | 21/23 | 7,0/7,6   |
|  | <b>Jeu complet avec 8 pieces</b>         | 25/27 | 8,3/9,0   |
|  | <b>Juego completo con 8 piezas</b>       | 29/31 | 9,6/10,3  |
|  | <b>Set completo dilatatori 8 pezzi</b>   | 33/35 | 11,0/11,6 |
|  |  | 37/39 | 12,3/13,0 |
|  |  | 41/43 | 13,6/14,3 |

French measure | Französische Maßnahme | Mesure française | Medida francesas | Misura francese

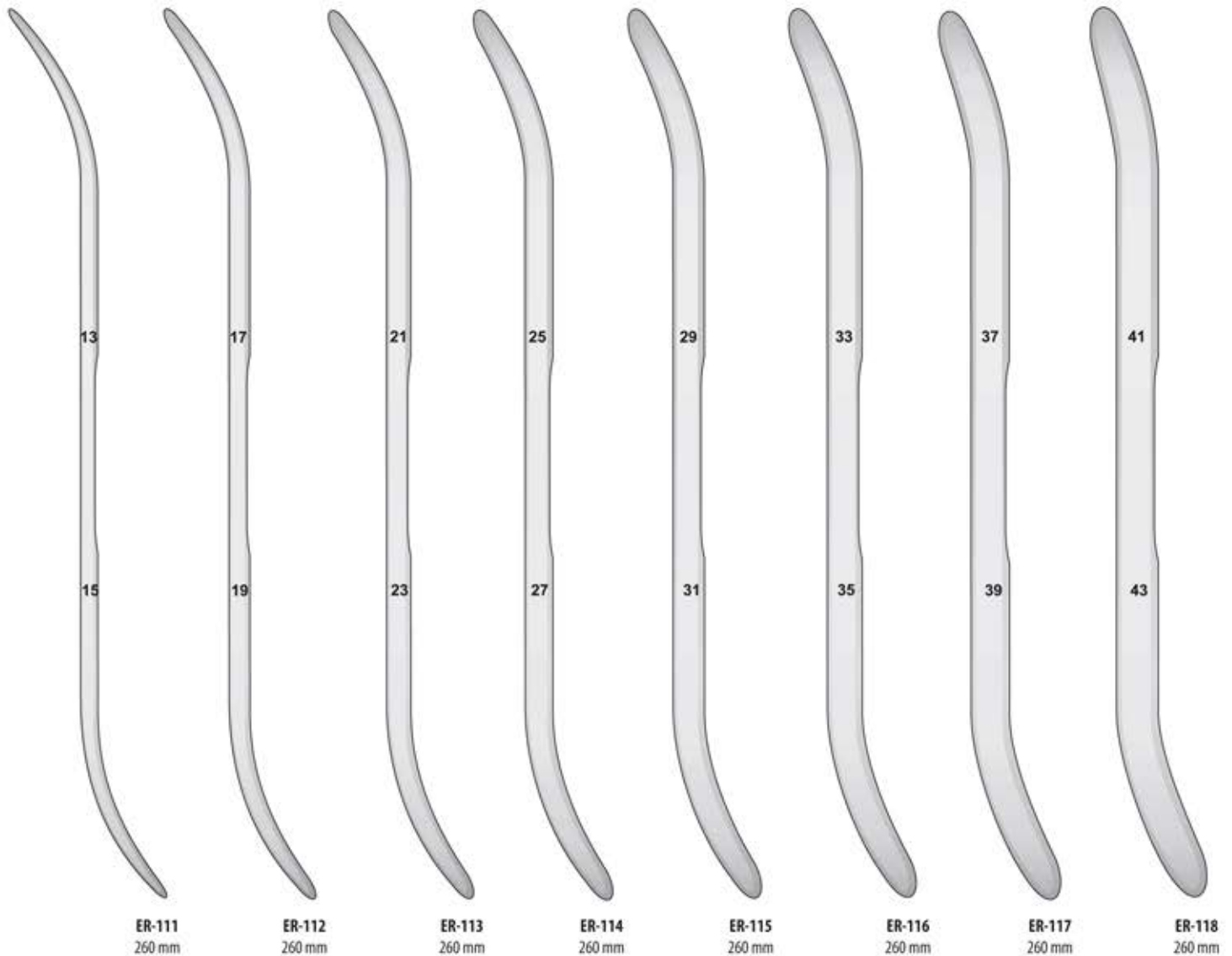

Uterine Dilators | Uterus-Dilatoren | Dilateurs utérins | Dilatadores uterinos | Dilatatori uterini

# Uterine Dilators

HEGAR  
EB-51/EB-93  
185 mm



|             |             |              |              |
|-------------|-------------|--------------|--------------|
| EB-51 1 mm  | EB-64 14 mm | EB-77 1½ mm  | EB-90 14½ mm |
| EB-52 2 mm  | EB-65 15 mm | EB-78 2½ mm  | EB-91 15½ mm |
| EB-53 3 mm  | EB-66 16 mm | EB-79 3½ mm  | EB-92 16½ mm |
| EB-54 4 mm  | EB-67 17 mm | EB-80 4½ mm  | EB-93 17½ mm |
| EB-55 5 mm  | EB-68 18 mm | EB-81 5½ mm  |              |
| EB-56 6 mm  | EB-69 19 mm | EB-82 6½ mm  |              |
| EB-57 7 mm  | EB-70 20 mm | EB-83 7½ mm  |              |
| EB-58 8 mm  | EB-71 21 mm | EB-84 8½ mm  |              |
| EB-59 9 mm  | EB-72 22 mm | EB-85 9½ mm  |              |
| EB-60 10 mm | EB-73 23 mm | EB-86 10½ mm |              |
| EB-61 11 mm | EB-74 24 mm | EB-87 11½ mm |              |
| EB-62 12 mm | EB-75 25 mm | EB-88 12½ mm |              |
| EB-63 13 mm | EB-76 26 mm | EB-89 13½ mm |              |



HANK  
ER-161  
260 mm

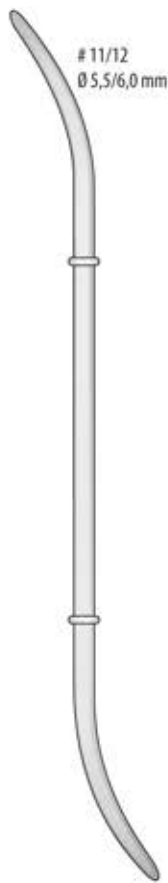

HANK  
ER-162  
260 mm

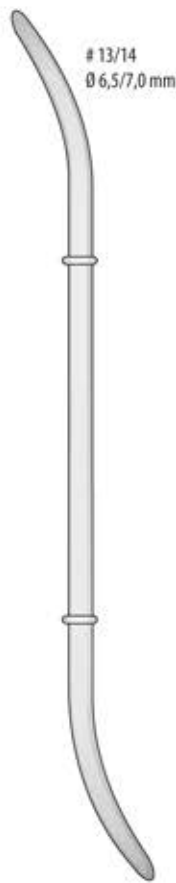

HANK  
ER-163  
260 mm



HANK  
ER-164  
260 mm

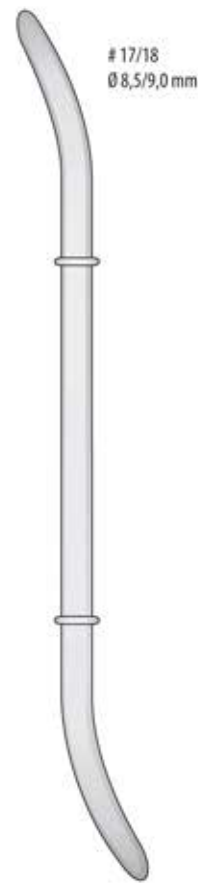

HANK  
ER-165  
260 mm

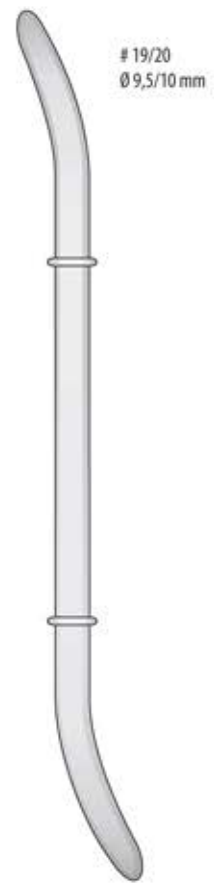

HANK  
ER-166  
260 mm

Uterine Dilators | Uterus-Dilatatoren | Dilatateurs utérins | Dilatadores uterinos | Dilatatori uterini



# Uterine Sounds

Graduated in centimeters | Zentimeter-einteilung | Gradué en centimètres | Graduado en centímetros | Graduati in centimetri

Flexible  
Flexibel  
Flexible  
Flexible  
Flessibile



SIMS  
ER-100/ER-102  
320 mm

Flexible  
Flexibel  
Flexible  
Flexible  
Flessibile



SIMPSON  
ER-103 Ø 3 mm  
320 mm

Rigid  
Fest  
Rigide  
Rigido  
Rigido

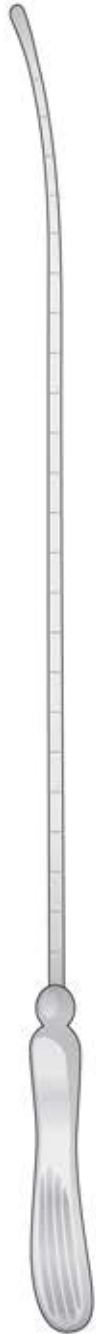

SIMS  
ER-104/ER-105  
320 mm

ER-104  
Ø 3 mm  
ER-105  
Ø 4 mm



VALLEIX  
ER-107 Ø 4 mm  
265 mm



MARTIN  
ER-106 Ø 3 mm  
300 mm

Flexible  
Flexibel  
Flexible  
Flexible  
Flessibile



MAYO  
ER-108 Ø 5 mm  
330 mm

Uterine Sounds | Uterussonden | Hystéromètres | Histerómetros | Isterometri

## Uterine Forceps

### Amniotome for the amnion bladder

Amniotom für die Amnionblase  
 Amniotome pour la vésicule amniotique  
 Amniótomo para la vesícula amniótica  
 Amniotomo per la vescica amniotica

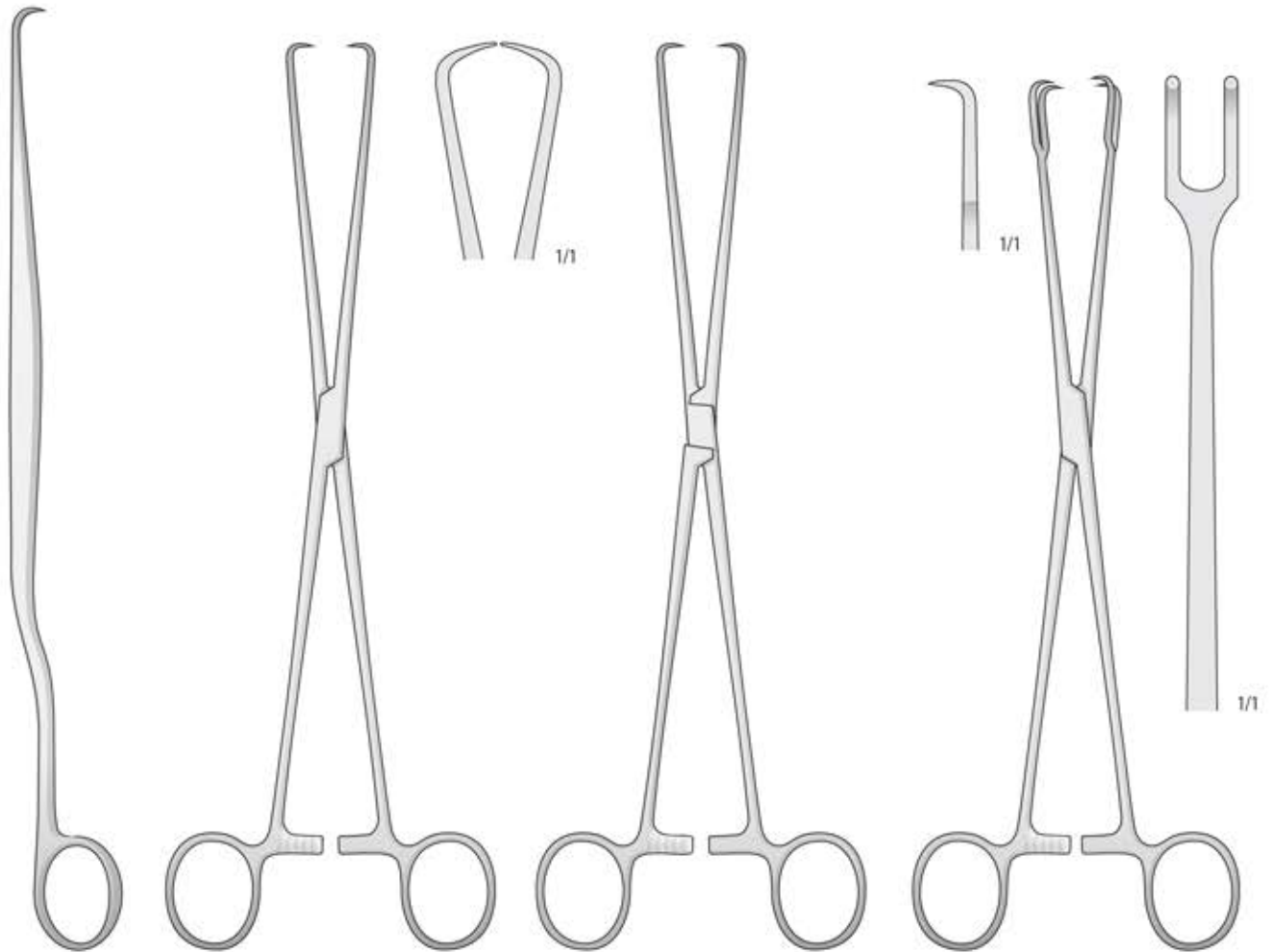

BEACHAM  
**BF-55**  
 260 mm

BRAUN  
**BF-49**  
 250 mm

POZZI  
**BF-60**  
 250 mm

SCHROEDER  
**BF-59**  
 240 mm

Uterine Forceps | Hakenzangen | Pinces utérines | Pinzas uterinas | Pinze uterine

## Uterine Forceps

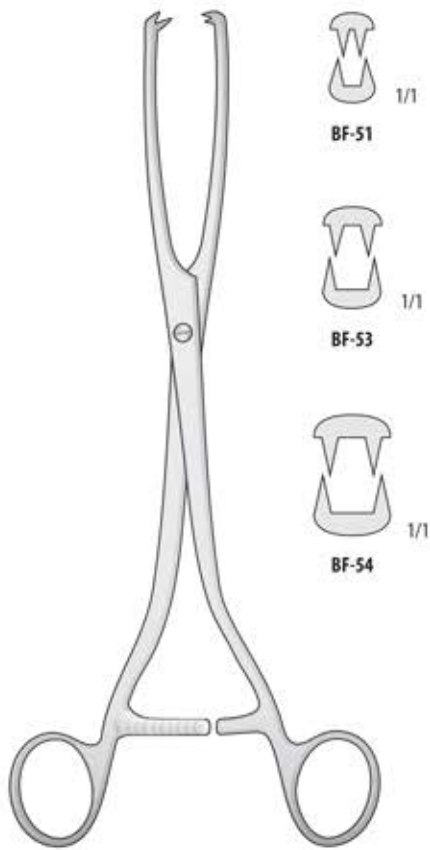

MUSEUX  
BF-51/BF-54  
240 mm



LITTLEWOOD  
EB-25  
185 mm

**Sideway Curved**  
Seitwärts Gebogen  
Courbes sur le côté  
Curvatura lateral  
Curvatura laterale

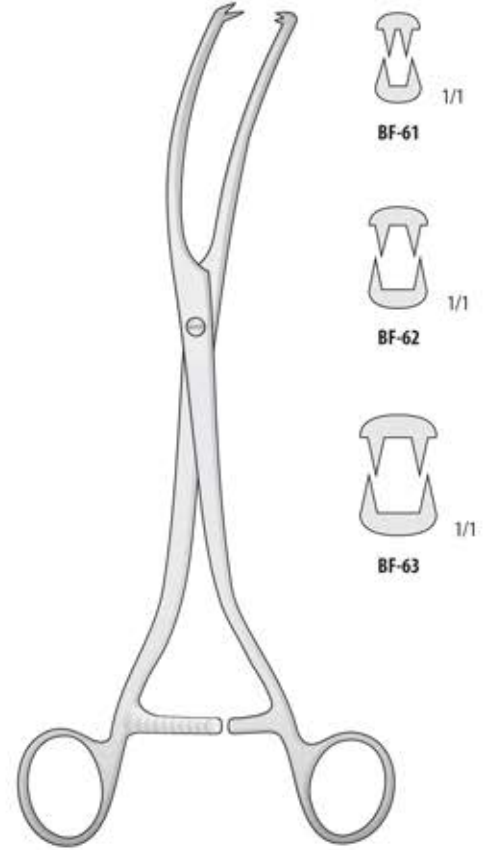

MUSEUX  
BF-61/BF-63  
240 mm

## Myoma | Micro-Tube Instruments



NEUBÜSER  
ER-150/ER-152  
200 mm

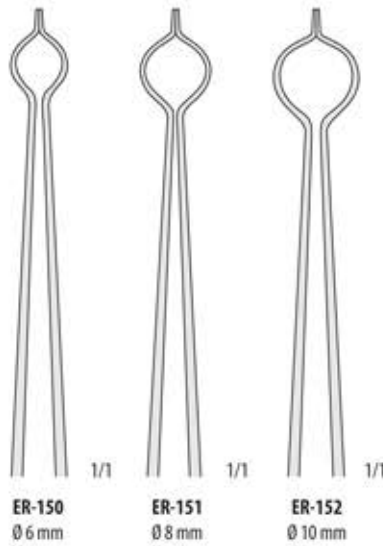

DOYEN  
EB-15  
150 mm

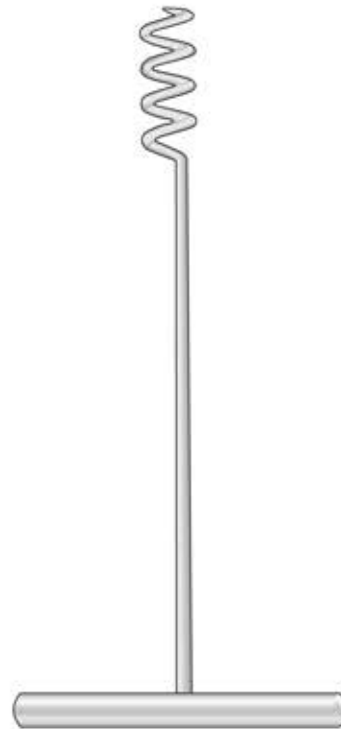

DOYEN  
EB-16  
170 mm

## Uterine Biopsy Aspirating Curettes

### Endometrial Biopsy curettes

Endometrium-Strickkürretten  
Curettes pour biopsie intra-utérines  
Curetas para biopsia endo-uterina  
Curette per biopsia endouterina

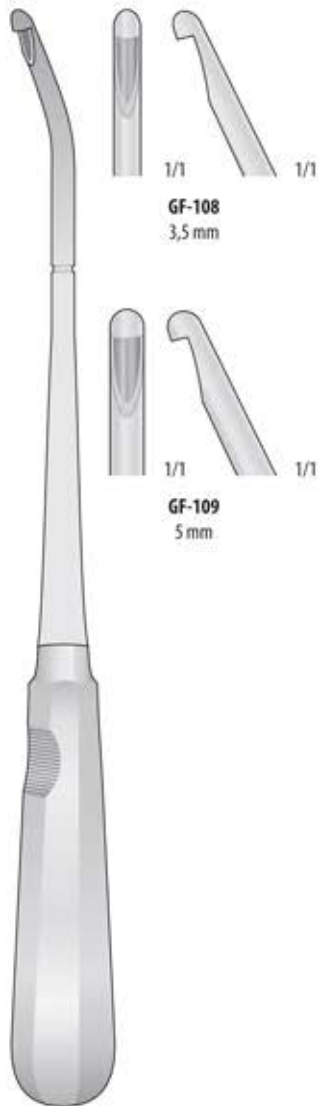

MÜNCHEN  
GF-108/GF-109  
270 mm



NOVAK  
GF-135/GF-138  
230 mm

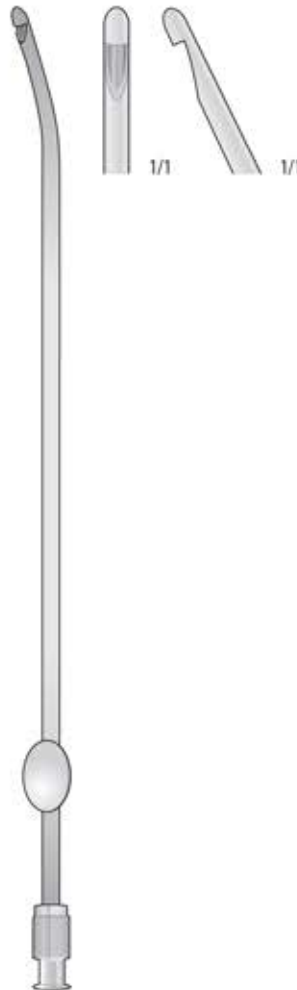

RANDALL  
GF-139  
230 mm

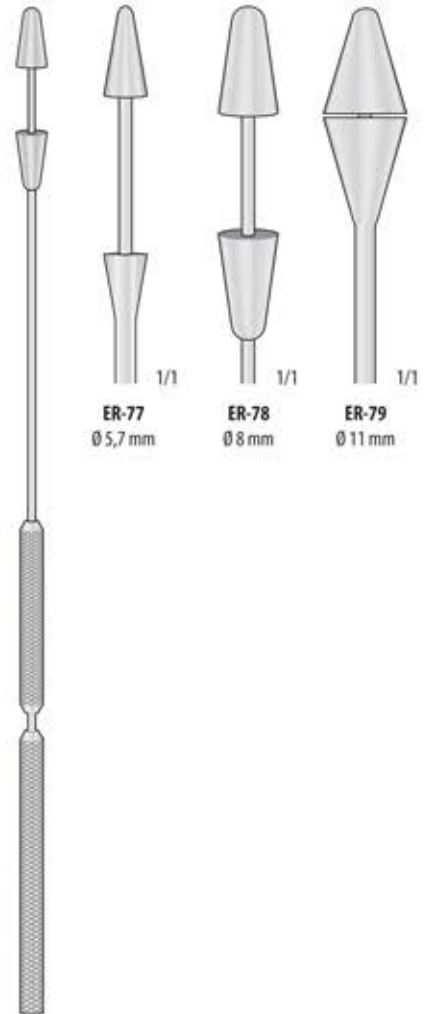

GUSBERG  
ER-77/ER-79  
240 mm

### Endocervical Biopsy Curettes

Endocervix-Biopsiekürretten  
Curettes pour biopsies endo-cervicales  
Curetas para biopsias endo-cervicales  
Curette per biopsia endocervicale

# Biopsy Forceps

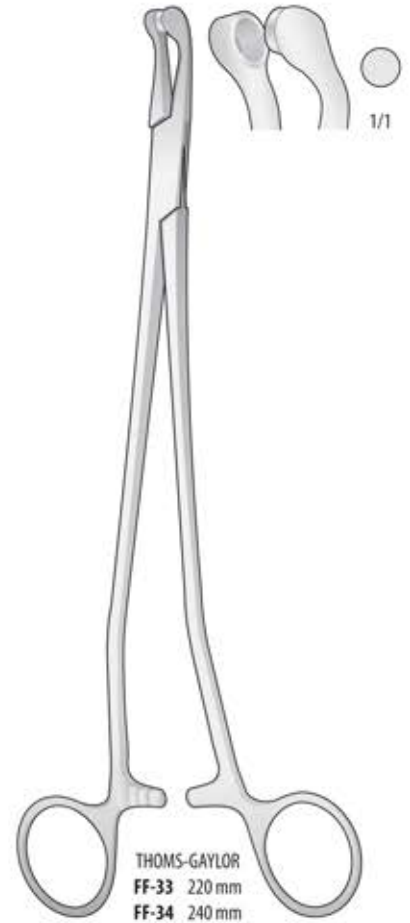
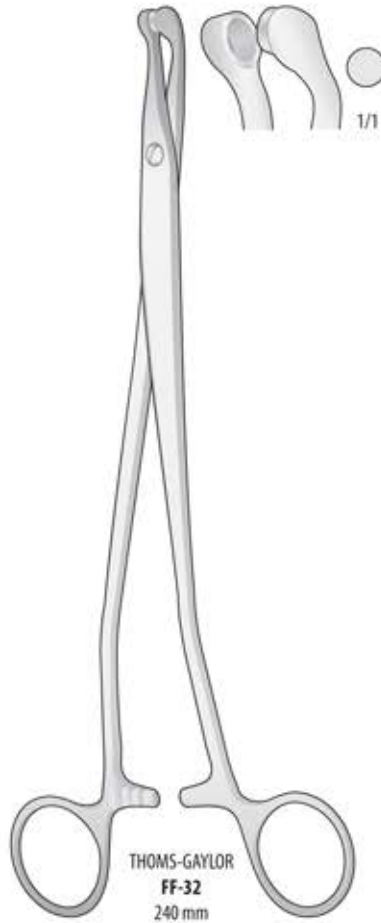
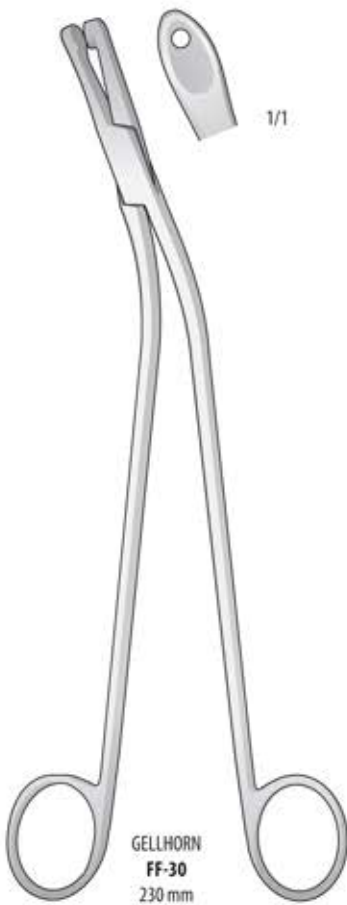

Biopsy Forceps | Biopsiezangen | Pinces pour biopsie | Pinzas para biopsia | Pinze per biopsia

# Biopsy Forceps

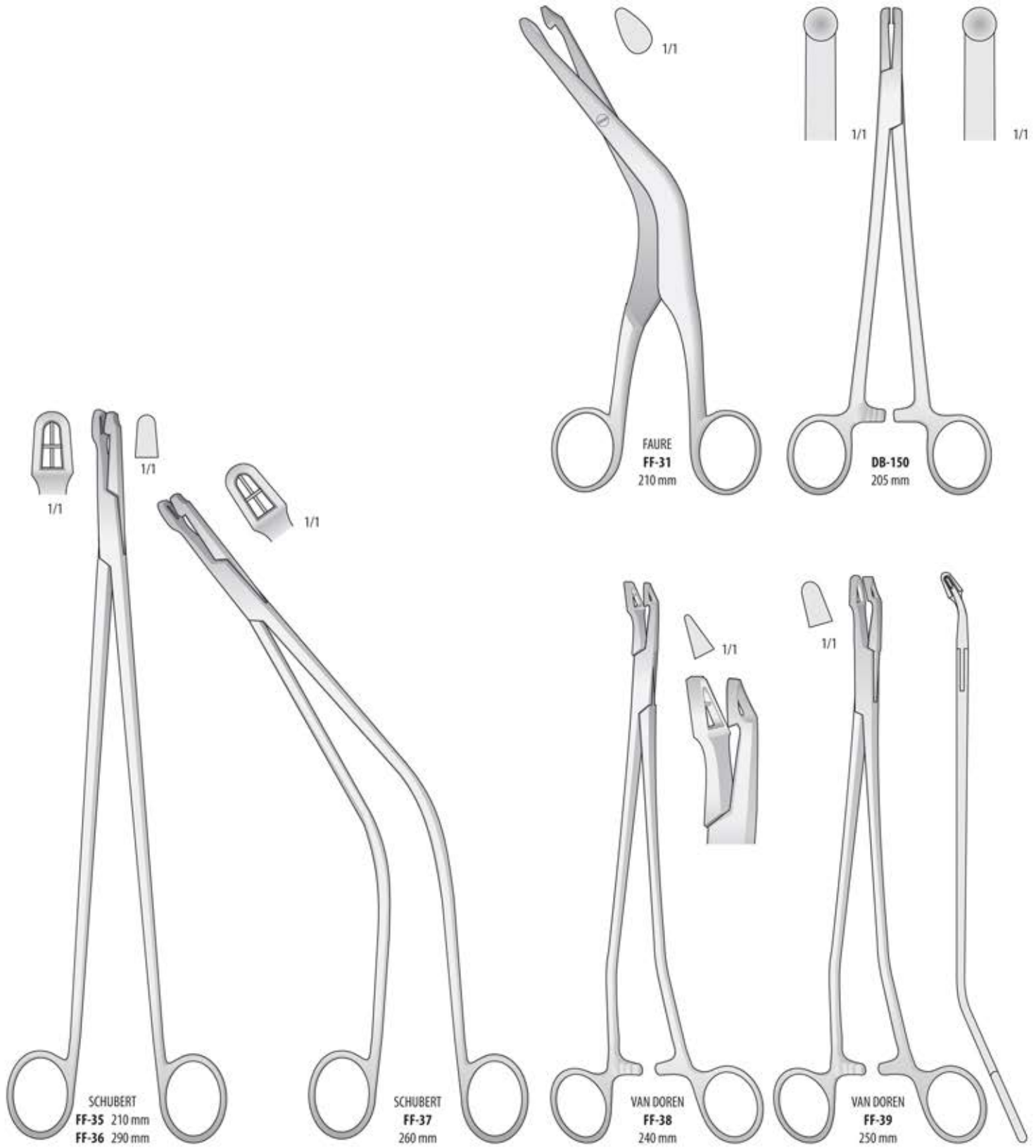

Biopsy Forceps | Biopsiezangen | Pinces pour biopsie | Pinzas para biopsia | Pinze per biopsia

## Biopsy Forceps

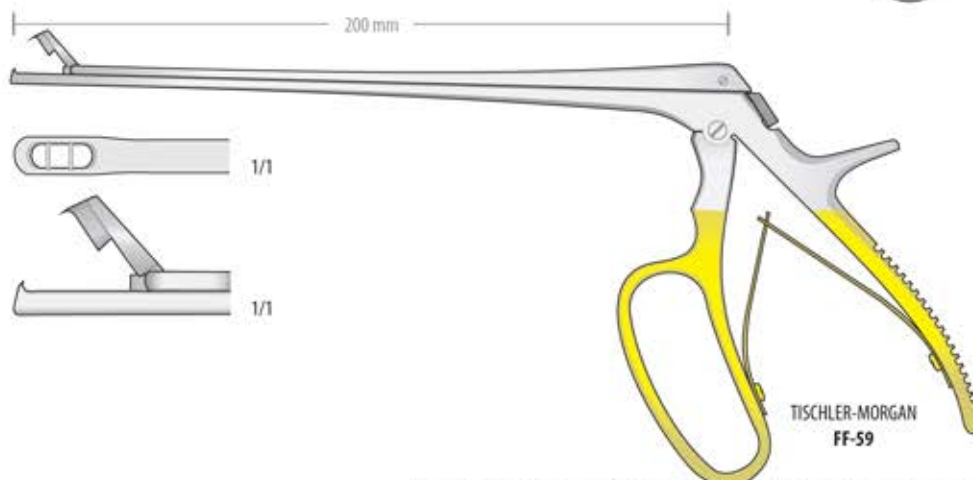
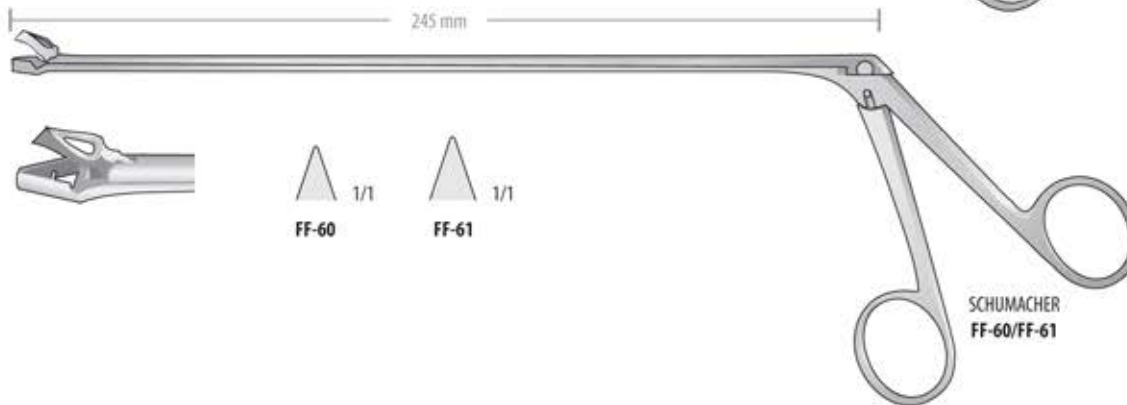
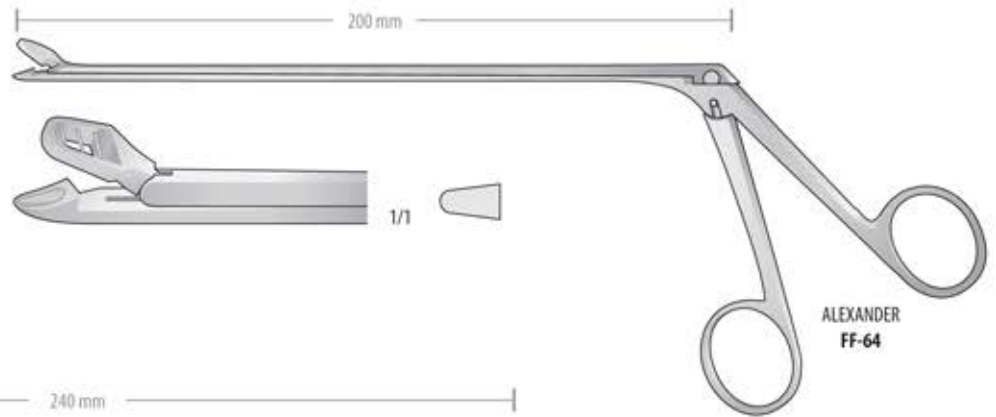

Biopsy Forceps | Biopsiezangen | Pinces pour biopsie | Pinzas para biopsia | Pinze per biopsia



## Uterine Curettes

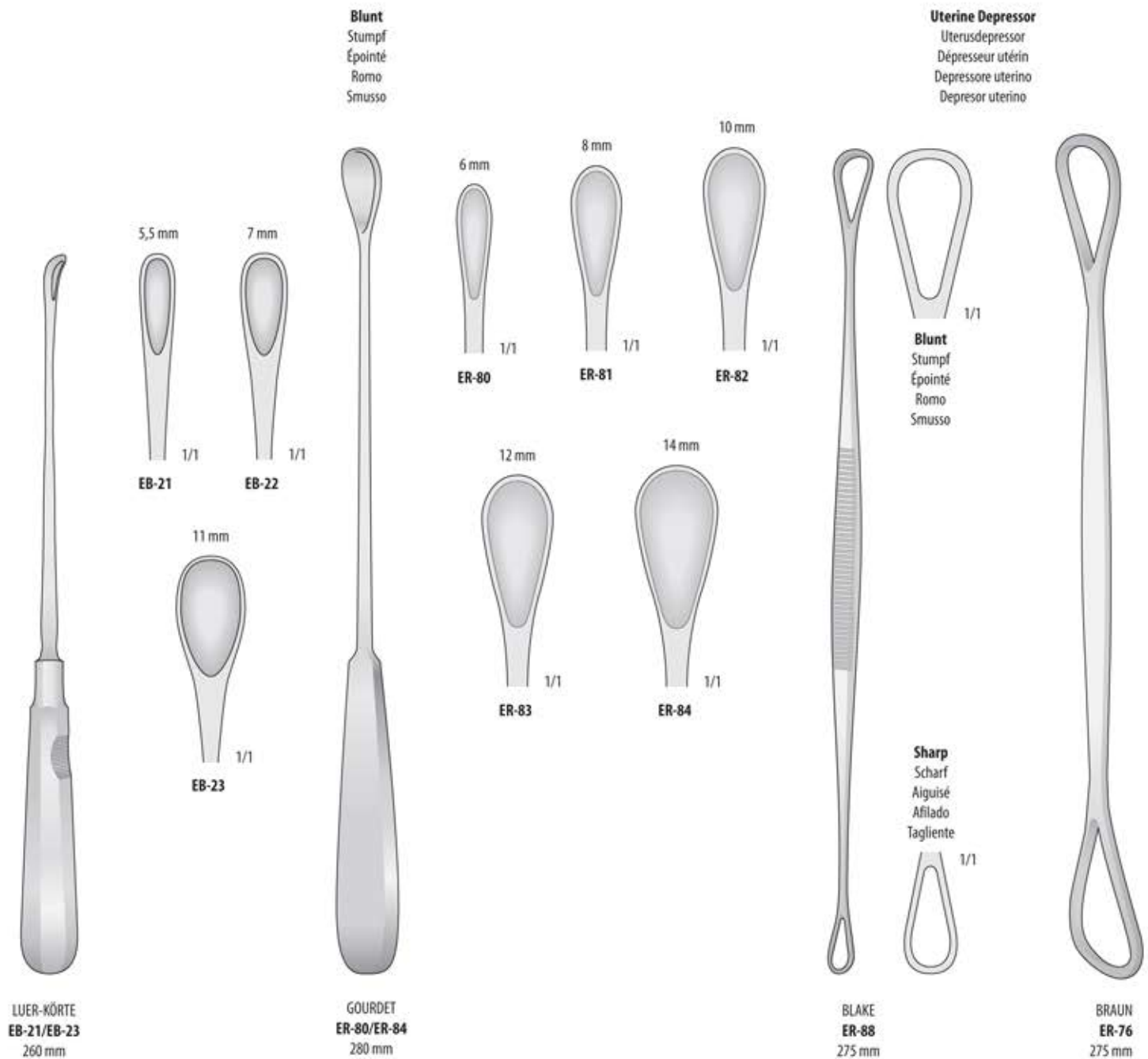

Uterine Curettes | Uterusküretten | Curettes autérines | Curetas uterinas | Curette uterine

## Uterine Curettes

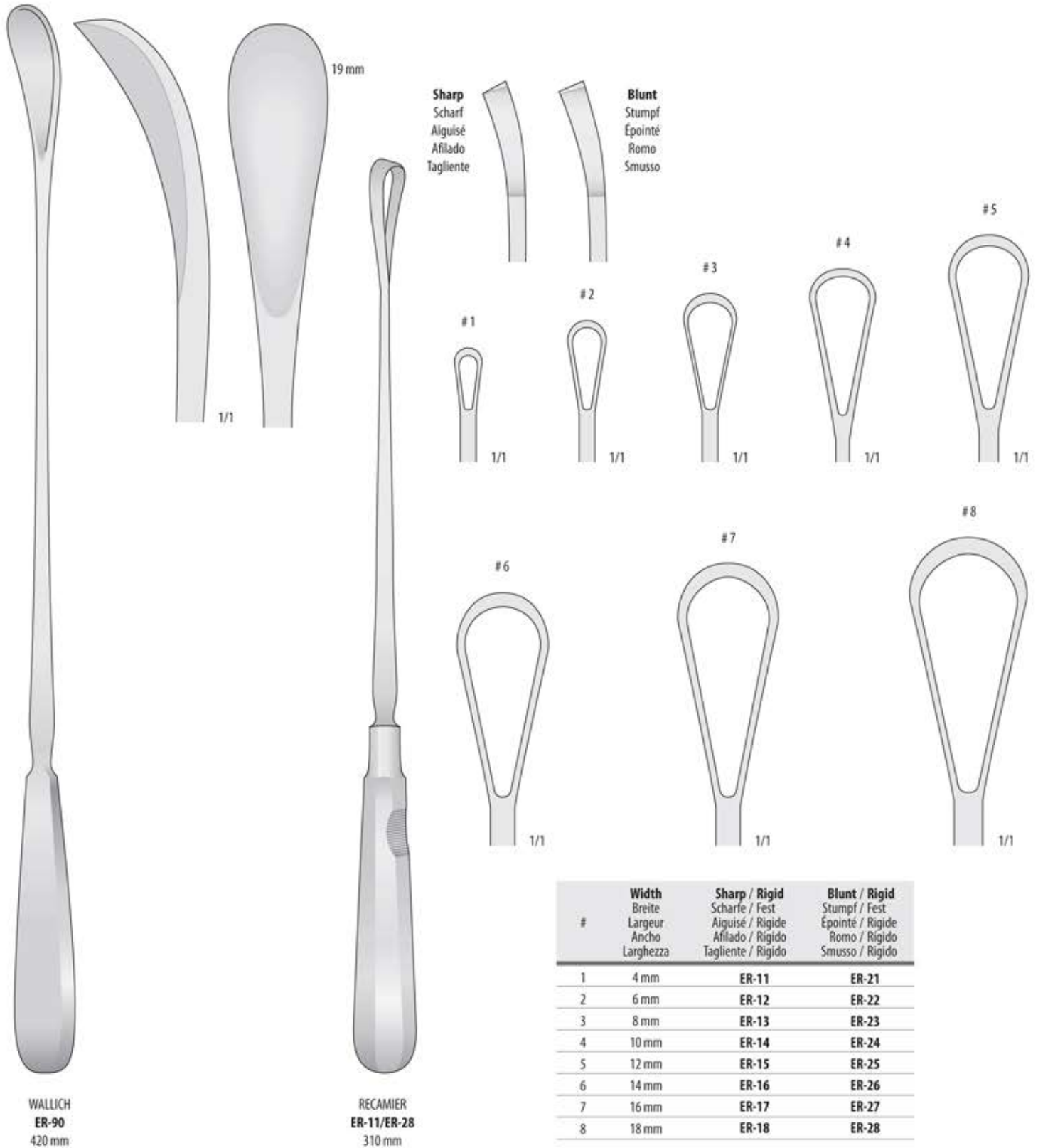

Uterine Curettes | Uterusküretten | Curettes autérines | Curetas uterinas | Curette uterine

# Uterine Curettes

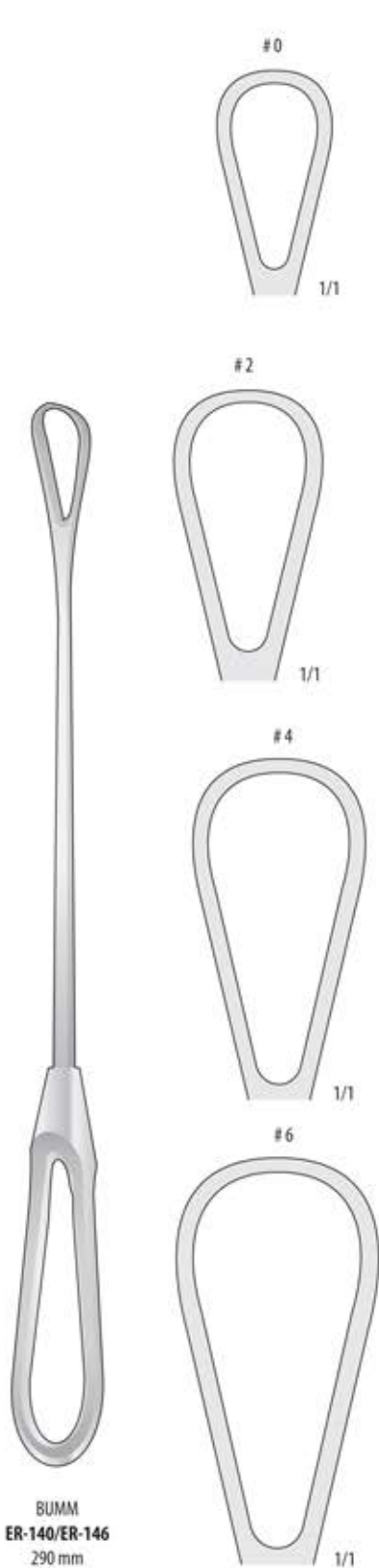

| # | Width<br>Breite<br>Largeur<br>Ancho<br>Larghezza | Blunt / Flexible<br>Stumpf / Flexibel<br>Épointé / Flexible<br>Romo / Flexible<br>Smusso / Flessibile |
|---|--|---|
| 0 | 16 mm  | ER-140  |
| 1 | 18 mm  | ER-141  |
| 2 | 19.5 mm  | ER-142  |
| 3 | 21.5 mm  | ER-143  |
| 4 | 23.5 mm  | ER-144  |
| 5 | 26 mm  | ER-145  |
| 6 | 28.5 mm  | ER-146  |

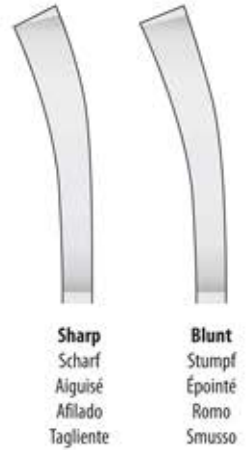

| # | Width<br>Breite<br>Largeur<br>Ancho<br>Larghezza | Sharp<br>Scharfe<br>Aiguisé<br>Afilado<br>Tagliente | Blunt<br>Stumpf<br>Épointé<br>Romo<br>Smusso |
|---|--|---|--|
| A | 18 mm  | ER-31   | ER-41  |
| B | 20 mm  | ER-32   | ER-42  |

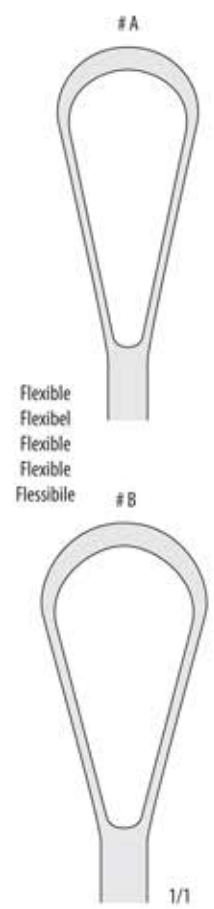

Uterine Curettes | Uterusküretten | Curettes autérines | Curetas uterinas | Curette uterine

# Cleaning, Maintenance and Sterilization of Surgical Instruments



## SHARPEN - LUBRICATE

India # 6  
Medium grit 100 x 45 mm  
4 x 1.8 in

Arkansas # 6A  
Fine texture



DB-3 DB-6A

### Wedge Stones

They combine flat surfaces with rounded edges to manually sharpen internal parts (straight and curved edges) of curettes and scalers.

*Arkansas:* for routine sharpening and finishing.

*India:* for sharpening of excessively dull instruments or those requiring recontouring.



DB-4

### Rectangular Stone

A flat and rectangular stone used to sharpen all cutting parts of surgical instruments.

Necessary in routine sharpening and finishing of edge and toe of an instrument.



DB-299

### Conical Stone

A cone-shaped and cylindrical stone used to manually sharpen internal parts of curettes, scalers, gouges, rongeurs, etc. (in areas that otherwise cannot be reached).



DB-96

### Flat Stone

A flat and rectangular stone used to sharpen all cutting parts of scissors, osteotomes, curettes, etc. (whenever necessary).



DB-0L

### Lubricating and Sharpening Oil

A non-coloured oil, which is an indispensable complement for lubricating and manual sharpening of surgical instruments. To activate the abrasive properties of Arkansas or India stones and to reduce the possibility of overheating the instruments during sharpening. It should be applied on all hinges or all other parts which are subject to movement or friction. Its use facilitates elimination of any residue present within the instrument hinges. Used to ensure perfect function and fluid movement of all surgical instruments. Must ALWAYS be used during all sharpening operations.



DB-71

### Ceramic Stone

Ceramic stones are valued for their durability and the very keen edge they give in the finer grits. Will never pit or groove. Used for routine sharpening procedures. Autoclave safe.

*Arkansas:* a natural stone extracted from the Arkansas mountains.  
*India:* a synthetic stone quarried from the finest Ozark novaculite-silicon quartz-deposits.

*Ceramic:* use only dry. (Do not use with oil, water or lubricants)

## RINSE - CLEAN

### CLEANLACT | Detergent Milk

Special milk for surgical instruments. Anticorrosive, bacteriostatic and lubricating action on all surgical instruments. Extends your instrument's lifetime. It guarantees perfect maintenance by eliminating eventual stains, halos and browning due to sterilization, disinfection and washing with tap water.

Must be applied periodically, diluted or concentrated. (see special instructions on packaging)



DB-50M 500 cc 17 oz  
DB-1L 1000 cc 34 oz

### Brushes | Autoclavables

Special brushes to clean surgical instruments. Used to remove eventual residue, organic or not, from all surgical instruments, in particular in angled, hinged and knurled parts, without damaging instrument surface.

Must be applied every time, for regular cleaning of all instrumentation and in the event that an instrument is exposed for an extended period to air before being immersed in the cleaning solution.



DB-11 155 mm 6 in  
DB-12 175 mm 7 in

### Special Rubbers for metal

50 x 40 x 20 mm / 2 x 1.6 x 0.8 in

An abrasive eraser specially designed for surgical instruments to remove stains, halos or persistent burnishing from all surgical instruments without damaging the instrument surface.

Necessary when routine cleaning does not remove all stains.



DB-08 Coarse  
DB-07 Fine

## STERILIZATION



Tray with clips and accessory bar

### Stainless Steel Cassettes

Silicone racks - Autoclavable

- BS-905<sup>1</sup> 5 instruments    BS-59<sup>1</sup>
- BS-910<sup>2</sup> 10 instruments    BS-60<sup>1</sup>
- BS-915<sup>3</sup> 15 instruments
- BS-920<sup>4</sup> 20 instruments    BS-61<sup>1</sup>

1.2 x 8 x (3<sup>1</sup>)(6<sup>2</sup>)(11<sup>3</sup>)(12<sup>4</sup>) in  
30 x 200 x (75<sup>1</sup>)(150<sup>2</sup>)(275<sup>3</sup>)(300<sup>4</sup>) mm  
Available only in North America



1.4 x 7 x (3<sup>1</sup>)(5.7<sup>2</sup>)(11.5<sup>3</sup>) in  
35 x 185 x (75<sup>1</sup>)(145<sup>2</sup>)(290<sup>3</sup>) mm

## TESTING

### Teflon Testing Stick

Ø 8 x 100 mm / Ø 0.3 x 3.5 in

A hard plastic stick used to test the blade of an instrument to determine the sharpness of an instrument.

Must be used ALWAYS. If the blade of the instrument runs smoothly over the plastic stick, then it is blunt. A sharp instrument will grab into the stick and removes small fragments of the plastic.



DB-15

## CODING

### Silicone Code Rings

- DB-941 120 Items
- DB-942 175 Items



# Maintenance Cycle and Tips

Wartungszyklus und Tipps | Cycle d'entretien et conseils | Ciclo de mantenimiento y consejos | Ciclo de manutenzione e consigli

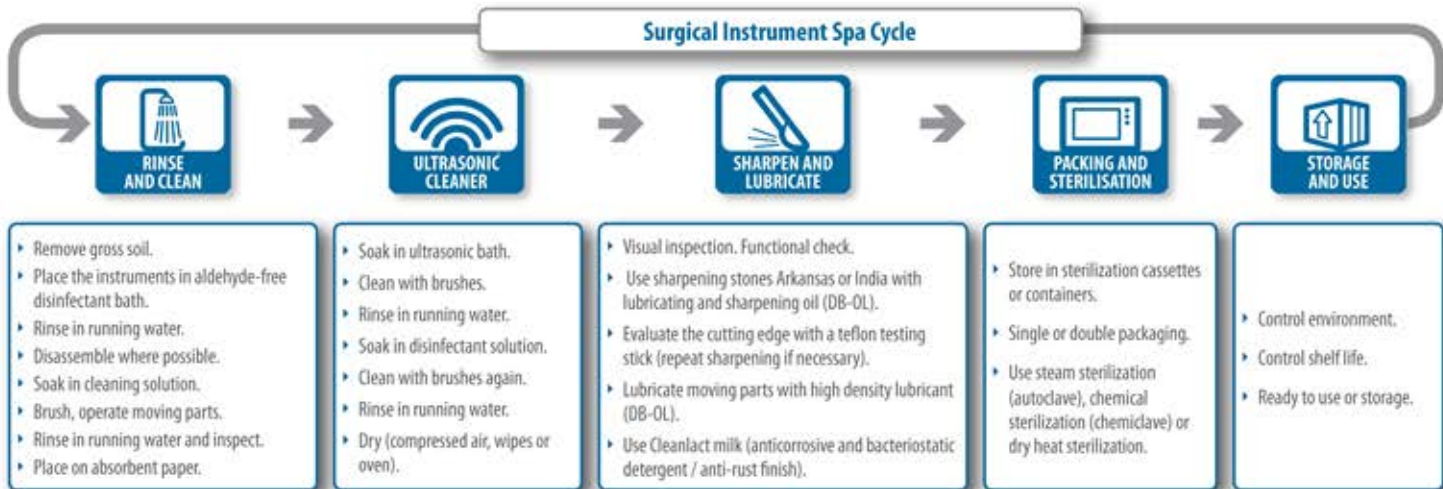

## SHARPEN YOUR INSTRUMENTS

### Why?

Surgical Instruments should be kept identical to their original design. Surgical procedures are most effective when using sharp instruments as they reduce hand and wrist fatigue, improve calculus removal, save time, improve tactile sensitivity, and minimize patient discomfort.

### When?

Instruments should be sharpened lightly after each use; there are two ways to evaluate whether the cutting edge is dull and requires sharpening:

- Visual:** The cutting edge should be inspected regularly in a good light (and if possible, under magnification). If the cutting edge is blunt it will be rounded and reflect the light. A dull, non-reflective line indicates sharpness.
- Teflon Test Stick (DB-15):** If the blade of the instrument runs smoothly over the testing stick, then it is blunt. A sharp instrument will grab into the stick and removes small fragments of the plastic.

### How?

Generally, the instruments should be sharpened following this procedure:

- Place one drop of sharpening oil (**DB-OL**) on the **Arkansas** sharpening stone. Lubrication improves the movement of the instrument blade over the stone; also, it prevents the metal particles from clogging the stone.
- Hold the instrument in one hand, while applying the stone to the lateral surface angled with the face of the blade.
- Position the stone to contact the heel of the blade and work toward the tip, keeping the stone in contact with the blade throughout the sharpening procedure.
- Move the stone up and down with short strokes, placing more pressure on the down stroke (do not move the instrument, keep the instrument still).
- Always finish instrument sharpening with a down stroke; this will prevent a rough edge from forming and remove any flash of metal.
- Evaluate the sharpness with teflon test stick (**DB-15**). If the blade is still dull, re-evaluate the angle of the stone and repeat the sharpening (steps 2-6).

## SHARPENING OF SCALERS AND CURETTES

**Sickle Scaler Toe End:** the sickle scaler has a pointed tip and, therefore, the stone is held straight as it nears the tip.

**Curette Toe End:** the curette has a rounded toe, so the position of the stone is adapted around the rounded cross-section.

**Always finish instrument sharpening with a down stroke; this will prevent a rough edge from forming and remove any flash of metal.**

**SHARP AND DELICATE INSTRUMENTS**  
Scissors, needle holders or bone forceps should be cleaned manually by using cleaning brushes.

**LUBRICATION**  
Regular use of **DB-OL** lubricant and sharpening oil and "Cleanlact" detergent will prevent rust, corrosion, and stiff joints.

**TC INSTRUMENTS**  
Tungsten carbide instruments are more sensitive to chemicals and require special care. They should never be exposed to chemical substances or to any other corrosive chemicals.

**SHARPENING**  
Regular sharpening will enhance the life of your cutter and will improve the quality of your work.

**ULTRASONIC CLEANING**  
It is not recommended for scissors, needle holders, bone forceps and all tungsten carbide instruments.

## RINSE AND CLEAN

Immediately after surgery, rinse instruments under warm running water (NOT HOT). Use only neutral detergent (pH=7).

## ULTRASONIC CLEANING

It is recommended for regular instruments such as hand instruments and extraction forceps, following this procedure:

- Sort instruments carefully so as to include only instruments compatible with ultrasonic cleaning. Do not combine different metals (stainless, copper, chrome plated, etc.).
- Place instruments in open position. Make certain sharp edges are not touching other instruments.
- Change solution frequently to avoid accumulation of micro organisms.
- After rinsing and before sterilization, inspect and dry the instruments thoroughly.

**⚠️ Ultrasonic cleaning does not sterilize. Do not use for TC instruments, sharp and delicate instruments.**

## STERILIZATION

### Autoclave (Steam Sterilization)

Time: 4 - 20 min. / Temperature: 130° - 134°C (266° / 273°F)

### Chemiclave (Chemical Sterilization)

Time: 4 - 20 min. / Temperature: 130° - 134°C (266° / 273°F)

### Dry Heat Sterilization (not recommended)

Time: 60 - 90 min. / Temperature: 160° - 170°C (320° / 340°F)

**⚠️ Sterilization cannot substitute cleaning.**

## CARE OF SHARPENING STONES

After use, wipe the stone with a clean cloth to remove metal particles. Then, clean the stone by scrubbing or using ultrasound to remove lubricant before sterilization. After sterilization, lubricate with **DB-OL** before each use.

**⚠️ Be sure to use entire stone to prevent "grooving".**

|            |                                |         |             |
|------------|--------------------------------|---------|-------------|
|            | CLEAN AND STERILIZE BEFORE USE |         |             |
| AUTOClave  | 132°C                          | 135°C   | TIME        |
| CHEMIClave | (270°F)                        | (273°F) | 5'-15'(min) |

# Alphanumerical Index

|         |    |       |    |        |    |        |    |        |    |        |    |        |    |
|---------|----|-------|----|--------|----|--------|----|--------|----|--------|----|--------|----|
| BF-01   | 11 | EA-78 | 5  | EB-79  | 24 | EB-158 | 14 | EB-253 | 7  | ER-92  | 12 | FB-329 | 6  |
| BF-02   | 11 | EA-79 | 5  | EB-80  | 24 | EB-160 | 14 | EB-254 | 7  | ER-93  | 12 | FB-330 | 6  |
| BF-03   | 11 | EA-90 | 5  | EB-80  | 33 | EB-162 | 14 | EB-255 | 7  | ER-96  | 12 | FB-331 | 6  |
| BF-04   | 11 | EA-91 | 5  | EB-81  | 24 | EB-163 | 14 | EB-256 | 7  | ER-97  | 12 | FB-332 | 6  |
| BF-18   | 10 | EA-92 | 5  | EB-81  | 33 | EB-164 | 14 | EB-257 | 7  | ER-100 | 25 | FB-333 | 6  |
| BF-19   | 10 | EA-93 | 5  | EB-82  | 24 | EB-166 | 14 | EB-258 | 7  | ER-101 | 25 | FB-334 | 6  |
| BF-30   | 11 | EA-94 | 20 | EB-82  | 33 | EB-170 | 16 | EB-259 | 7  | ER-102 | 25 | FB-335 | 6  |
| BF-31   | 11 | EB-11 | 4  | EB-83  | 24 | EB-171 | 16 | EB-260 | 7  | ER-103 | 25 | FB-336 | 6  |
| BF-32   | 10 | EB-12 | 4  | EB-83  | 33 | EB-172 | 16 | EB-261 | 7  | ER-104 | 25 | FB-337 | 6  |
| BF-33   | 10 | EB-13 | 4  | EB-84  | 24 | EB-173 | 16 | EB-262 | 7  | ER-105 | 25 | FB-338 | 6  |
| BF-34   | 10 | EB-14 | 4  | EB-84  | 33 | EB-174 | 16 | EB-263 | 7  | ER-106 | 25 | FB-339 | 6  |
| BF-35   | 10 | EB-15 | 28 | EB-85  | 24 | EB-175 | 16 | EB-264 | 7  | ER-107 | 25 | FB-340 | 6  |
| BF-49   | 26 | EB-16 | 28 | EB-86  | 24 | EB-176 | 16 | EB-265 | 7  | ER-108 | 25 | FB-341 | 6  |
| BF-51   | 27 | EB-17 | 18 | EB-87  | 24 | EB-177 | 16 | EB-266 | 7  | ER-110 | 23 | FB-342 | 6  |
| BF-53   | 27 | EB-18 | 6  | EB-88  | 24 | EB-178 | 16 | EB-267 | 7  | ER-111 | 23 | FB-343 | 6  |
| BF-54   | 27 | EB-19 | 6  | EB-88  | 33 | EB-179 | 16 | EB-290 | 19 | ER-112 | 23 | FF-30  | 30 |
| BF-55   | 26 | EB-20 | 6  | EB-89  | 24 | EB-184 | 16 | EB-291 | 19 | ER-113 | 23 | FF-31  | 31 |
| BF-56   | 18 | EB-21 | 33 | EB-90  | 24 | EB-189 | 16 | EB-292 | 19 | ER-114 | 23 | FF-32  | 30 |
| BF-57   | 18 | EB-22 | 33 | EB-91  | 24 | EB-190 | 16 | EB-293 | 19 | ER-115 | 23 | FF-33  | 30 |
| BF-59   | 26 | EB-23 | 33 | EB-92  | 24 | EB-191 | 16 | EB-294 | 19 | ER-116 | 23 | FF-34  | 30 |
| BF-60   | 26 | EB-25 | 27 | EB-94  | 22 | EB-201 | 7  | EB-295 | 19 | ER-117 | 23 | FF-35  | 31 |
| BF-61   | 27 | EB-30 | 9  | EB-95  | 22 | EB-202 | 7  | ER-11  | 34 | ER-118 | 23 | FF-36  | 31 |
| BF-62   | 27 | EB-31 | 9  | EB-96  | 22 | EB-203 | 7  | ER-12  | 34 | ER-120 | 21 | FF-37  | 31 |
| BF-63   | 27 | EB-32 | 9  | EB-97  | 22 | EB-204 | 7  | ER-13  | 34 | ER-121 | 21 | FF-38  | 31 |
| BF-96   | 9  | EB-36 | 4  | EB-100 | 14 | EB-205 | 7  | ER-14  | 34 | ER-122 | 21 | FF-39  | 31 |
| BF-97   | 9  | EB-37 | 4  | EB-101 | 14 | EB-206 | 7  | ER-15  | 34 | ER-123 | 21 | FF-59  | 32 |
| BF-100  | 8  | EB-38 | 4  | EB-102 | 14 | EB-207 | 7  | ER-16  | 34 | ER-124 | 21 | FF-60  | 32 |
| BS-17   | 22 | EB-39 | 4  | EB-103 | 14 | EB-208 | 7  | ER-17  | 34 | ER-125 | 21 | FF-61  | 32 |
| BS-59   | 36 | EB-42 | 7  | EB-104 | 14 | EB-209 | 7  | ER-18  | 34 | ER-126 | 21 | FF-62  | 32 |
| BS-60   | 36 | EB-43 | 7  | EB-105 | 14 | EB-210 | 7  | ER-21  | 34 | ER-127 | 21 | FF-64  | 32 |
| BS-61   | 36 | EB-44 | 7  | EB-106 | 14 | EB-211 | 7  | ER-22  | 34 | ER-128 | 21 | GF-108 | 29 |
| CT-555N | 36 | EB-45 | 7  | EB-107 | 14 | EB-212 | 7  | ER-23  | 34 | ER-129 | 21 | GF-109 | 29 |
| CT-556N | 36 | EB-46 | 7  | EB-110 | 20 | EB-213 | 7  | ER-24  | 34 | ER-130 | 21 | GF-135 | 29 |
| CT-560N | 36 | EB-47 | 7  | EB-111 | 20 | EB-214 | 7  | ER-25  | 34 | ER-131 | 21 | GF-136 | 29 |
| CT-564N | 36 | EB-48 | 7  | EB-117 | 18 | EB-215 | 7  | ER-26  | 34 | ER-132 | 21 | GF-137 | 29 |
| CT-565N | 36 | EB-49 | 7  | EB-118 | 18 | EB-216 | 7  | ER-27  | 34 | ER-133 | 22 | GF-138 | 29 |
| CT-569N | 36 | EB-51 | 24 | EB-119 | 18 | EB-217 | 7  | ER-28  | 34 | ER-134 | 22 | GF-139 | 29 |
| DB-07   | 36 | EB-52 | 24 | EB-120 | 15 | EB-218 | 7  | ER-31  | 35 | ER-135 | 22 | GS-13  | 4  |
| DB-08   | 36 | EB-53 | 24 | EB-121 | 15 | EB-219 | 7  | ER-32  | 35 | ER-140 | 35 | GS-14  | 4  |
| DB-1L   | 36 | EB-54 | 24 | EB-122 | 15 | EB-220 | 7  | ER-41  | 35 | ER-141 | 35 | P-99   | 8  |
| DB-3    | 36 | EB-55 | 24 | EB-123 | 15 | EB-221 | 7  | ER-42  | 35 | ER-142 | 35 | P-224  | 8  |
| DB-5    | 36 | EB-56 | 24 | EB-124 | 15 | EB-222 | 7  | ER-46  | 12 | ER-143 | 35 | P-225  | 8  |
| DB-6A   | 36 | EB-57 | 24 | EB-125 | 15 | EB-223 | 7  | ER-47  | 12 | ER-144 | 35 | P-226  | 8  |
| DB-10M  | 36 | EB-58 | 24 | EB-126 | 15 | EB-231 | 6  | ER-48  | 12 | ER-145 | 35 |        |    |
| DB-11   | 36 | EB-59 | 24 | EB-127 | 15 | EB-232 | 6  | ER-49  | 12 | ER-146 | 35 |        |    |
| DB-12   | 36 | EB-60 | 24 | EB-128 | 15 | EB-233 | 6  | ER-50  | 17 | ER-150 | 28 |        |    |
| DB-15   | 36 | EB-61 | 24 | EB-130 | 15 | EB-234 | 6  | ER-51  | 17 | ER-151 | 28 |        |    |
| DB-50M  | 36 | EB-62 | 24 | EB-131 | 15 | EB-235 | 6  | ER-52  | 17 | ER-152 | 28 |        |    |
| DB-96   | 36 | EB-63 | 24 | EB-132 | 15 | EB-236 | 6  | ER-53  | 17 | ER-161 | 24 |        |    |
| DB-150  | 31 | EB-64 | 24 | EB-133 | 15 | EB-237 | 6  | ER-58  | 13 | ER-162 | 24 |        |    |
| DB-299  | 36 | EB-65 | 24 | EB-134 | 15 | EB-238 | 6  | ER-59  | 13 | ER-163 | 24 |        |    |
| DB-0L   | 36 | EB-66 | 24 | EB-135 | 15 | EB-239 | 6  | ER-60  | 13 | ER-164 | 24 |        |    |
| DB-0LR  | 36 | EB-67 | 24 | EB-136 | 15 | EB-240 | 6  | ER-61  | 12 | ER-165 | 24 |        |    |
| EA-60   | 5  | EB-68 | 24 | EB-137 | 15 | EB-241 | 6  | ER-62  | 12 | ER-166 | 24 |        |    |
| EA-62   | 5  | EB-69 | 24 | EB-138 | 15 | EB-242 | 6  | ER-63  | 12 | FB-41  | 9  |        |    |
| EA-63   | 5  | EB-70 | 24 | EB-139 | 15 | EB-243 | 6  | ER-72  | 12 | FB-43  | 8  |        |    |
| EA-64   | 5  | EB-71 | 24 | EB-140 | 15 | EB-244 | 6  | ER-73  | 12 | FB-320 | 6  |        |    |
| EA-65   | 5  | EB-72 | 24 | EB-141 | 15 | EB-245 | 6  | ER-74  | 12 | FB-321 | 6  |        |    |
| EA-66   | 5  | EB-73 | 24 | EB-142 | 15 | EB-246 | 6  | ER-77  | 29 | FB-322 | 6  |        |    |
| EA-67   | 5  | EB-74 | 24 | EB-143 | 15 | EB-247 | 6  | ER-78  | 29 | FB-323 | 6  |        |    |
| EA-70   | 5  | EB-75 | 24 | EB-150 | 14 | EB-248 | 6  | ER-79  | 29 | FB-324 | 6  |        |    |
| EA-72   | 5  | EB-76 | 24 | EB-151 | 14 | EB-249 | 6  | ER-87  | 18 | FB-325 | 6  |        |    |
| EA-74   | 5  | EB-76 | 33 | EB-152 | 14 | EB-250 | 6  | ER-89  | 18 | FB-326 | 6  |        |    |
| EA-76   | 5  | EB-77 | 24 | EB-156 | 14 | EB-251 | 7  | ER-90  | 34 | FB-327 | 6  |        |    |
| EA-77   | 5  | EB-78 | 24 | EB-157 | 14 | EB-252 | 7  | ER-91  | 12 | FB-328 | 6  |        |    |

### Dental

Dentalchirurgie  
Allgemeine Zahnmedizin  
Implantologie  
Kieferorthopädie  
Endodontie  
Parodontologie  
Knochenregeneration  
Mund-, Kiefer- und Gesichtschirurgie

### Dentaire

Chirurgie dentaire  
Odontologie  
Implantologie  
Orthodontie  
Endodontie  
Parodontie  
Régénération osseuse  
Chirurgie buccale et maxillo-faciale

### Dental

Crugia dental  
Odontologia general  
Implantologia  
Ortodoncia  
Endodoncia  
Periodoncia  
Regeneración ósea  
Crugia oral y maxilofacial

### Dentale

Chirurgia Dentale  
Odontoiatria generale  
Implantologia  
Ortodonzia  
Endodonzia  
Parodontologia  
Rigenerazione assea  
Chirurgia maxillo-facciale 11



### Dental

Dental Surgery  
General Dentistry  
Implantology  
Orthodontics  
Endodontics  
Periodontics  
Bone Regeneration  
Oral and Maxillofacial Surgery

### Plastische Chirurgie

Rekonstruierende Chirurgie  
Kosmetische Chirurgie  
Blepharoplastik  
Brust-Chirurgie  
Rhinoplastik  
Fettabsaugung  
Gesichtsstraffung | Facelift  
Mund-, Kiefer- und Gesichtschirurgie

### Chirurgie Plastique

Chirurgie reconstructive  
Chirurgie esthétique  
Blépharoplastie  
Chirurgie mammaire  
Rhinoplastie  
Liposuction  
Rhytidectomie | Lifting faciale  
Chirurgie buccale et maxillo-faciale

### Crugia Plástica

Crugia reconstructiva  
Crugia estética  
Blefaroplastia  
Crugia mamaria  
Rinoplastia  
Liposucción  
Ritidectomia | Lifting facial  
Crugia oral y maxilofacial

### Chirurgia Plastica

Chirurgia ricostruttiva  
Chirurgia estetica  
Blefaroplastica  
Chirurgia del seno  
Rinoplastica  
Liposuzione  
Ritidectomia | Lift facciale  
Chirurgia maxillo-facciale



### Plastic Surgery

Reconstructive Surgery  
Cosmetic Surgery  
Blepharoplasty  
Breast Surgery  
Rhinoplasty  
Liposuction  
Rhytidectomy | Facelift  
Oral and Maxillofacial Surgery

### Allgemeine Chirurgie und Spezialgebiete

Allgemeine Chirurgie  
Arthroskopie  
Gynäkologie  
Mikrochirurgie  
Ophthalmologie  
HNO | Heilkunde  
Traumatologie | Orthopädie  
Podologie | Pediküre | Ästhetik

### Chirurgie Générale et Spécialités

Chirurgie générale  
Arthroscopie  
Gynécologie  
Microchirurgie  
Ophtalmologie  
ORL | Oto-rhino-laryngologie  
Traumatologie | Orthopédie  
Podologie | Pédiçure | Esthétique

### Crugia General y Especialidades

Crugia general  
Artroscopia  
Ginecologia  
Microcirugia  
Oftalmologia  
ORL | Otorrinolaringologia  
Traumatologia | Ortopedia  
Podologia | Pedicura | Estética

### Chirurgia Generale e Specializzazioni

Chirurgia generale  
Artroscopia  
Ginecologia  
Microchirurgia  
Oftalmologia  
ORL | Otorinolaringoiatria  
Traumatologia | Ortopedia  
Podologia | Pedicure | Estetica



### General Surgery and Specialties

General Surgery  
Arthroscopy  
Gynecology  
Microsurgery  
Ophthalmology  
ENT | Otolaryngology  
Traumatology | Orthopaedics  
Podiatry | Pedicure | Esthetics

### Veterinärmedizin

Allgemeine Chirurgie  
Zahnärztliche Chirurgie  
Dermatologie  
Ophthalmologie  
HNO | Heilkunde  
Traumatologie | Orthopädie  
Vögel | Hunde | Katzen | Rinder | Haustiere  
Reptilien | Exoten | Zoo- und Wildtierforschung

### Vétérinaire

Chirurgie générale  
Chirurgie dentaire  
Dermatologie  
Ophtalmologie  
ORL - Oto-rhino-laryngologie  
Traumatologie | Orthopédie  
Oiseaux | Canines | Felines | Bovines | Equines  
Reptiles | Exotiques | Zoo et sauvages

### Veterinaria

Crugia General  
Crugia oral  
Dermatologia  
Oftalmologia  
ORL | Otorinolaringologia  
Traumatologia | Ortopedia  
Aves | Caninos | Felinos | Bovinos | Equinos  
Reptiles | Exóticos | Zoológico y salvajes

### Veterinaria

Chirurgia generale  
Chirurgia orale  
Dermatologia  
Oftalmologia  
ORL | Otorinolaringoiatria  
Traumatologia | Ortopedia  
Birds | Canine | Feline | Bovini | Equini  
Reptile | Esotici | Zoo e selvaggio



### Veterinary

General Surgery  
Dental Surgery  
Dermatology  
Ophthalmology  
ENT | Otolaryngology  
Traumatology | Orthopaedics  
Birds | Canine | Feline | Bovine | Equine  
Reptile | Exotics | Zoo and wildlife

